

AR8/16 ELITE MANUAL

Axiom Tool Group, Inc. has provided this manual covering the safe operation and maintenance procedures for the AutoRoute™ Elite series machines. Contained in the manual are installation instructions, safety precautions, operational procedures and maintenance guidelines.

The instructions set forth in this document, will ensure that the AutoRoute™ machine will provide consistent, long-term operation.

This manual was not intended to cover every facet of machine operation. The use of jigs, fixtures, after market CNC accessories, choice of materials and tooling may require additional research. Online forums, and CNC blogs are a good source of knowledge from experienced users.

Regardless of the methods in place, personal safety is always a priority.

If you have any questions or comments, please email the Axiom Precision Customer Service team at support@axiomtoolgroup.com.

Safety Information

The AutoRoute™ is an electrical appliance and precision machine. Protect yourself and your investment. Read and understand the entire owner's manual before attempting assembly or operation. Read and understand the warnings posted on the machine and in this manual. Failure to comply with all the warnings may cause serious personal injury or costly damage to your AutoRoute™.

This AutoRoute™ CNC machine is designed and intended for use by properly trained and experienced personnel only. If you are not familiar with the proper and safe operation of a CNC machine, do not use the AutoRoute™ until proper training and knowledge have been obtained.

Your AutoRoute™ machine is intended for cutting wood, acrylics, wood-fiber composites, certain plastics and non-ferrous metals. Do not use this machine for other than its intended use. If used for other purposes, Axiom disclaims any real or implied warranty and holds itself harmless from any injury that may result from that use.

Shop Environment

1. Ensure that the floor can bear the weight of the machine and work pieces mounted on it.
2. Keep the floor around the machine clean and free of scrap material, oil and grease.
3. Do not lean lumber or other heavy materials against the gantry, guide rails or table.
4. Support the weight of the dust hose attached to the dust shoe accessory to prevent the weight of the hose from dislodging the dust shoe. Ensure that there is sufficient slack in the dust collection hose to allow the spindle to cover the entire work area.
5. Locate the AutoRoute™ away from overhead pipes and plumbing fixtures to prevent condensation from dripping on to the spoil boards and control system components.
6. Locate the AutoRoute™ away from sinks, faucets or other water supplies or storage to prevent splash-out that can damage the spoil boards and control system components.
7. Provide adequate room between the AutoRoute™ and other machines in the shop to reduce the chance of accidental jarring when transporting lumber or other heavy materials through the shop and while materials are being worked on other machines.
8. Ensure adequate space between machines to allow for the possibility that the work piece will extend over the end of the AutoRoute™ table.
9. Store cutting tools in a dry location and prevent contact to preserve the cutting edges.

Health and Safety

10. Always wear approved personal health and safety equipment as indicated for the materials and type of operations that will be performed. These should include a dust mask, hearing protection, safety clothing, and safety glasses/face shield. Do not rely on prescription or over-the-counter eyeglasses; they are *not* safety glasses. Wear ear protectors (plugs or muffs) even during short periods of operation.
11. Before operating this machine; remove any hand, wrist, and neck jewelry and roll sleeves up past the elbows. Be sure to not wear loose clothing which may become caught in the machine and confine long hair.
 - a. Non-slip footwear or anti-skid floor strips are recommended.
12. Use a dust mask or other safeguards to avoid inhaling dust generated from wood products. Install dust collection equipment consistent with shop ventilation practices and budget. Remove dust and debris from the floor frequently to prevent slipping. Drilling, sawing, sanding or machining wood products generates wood dust and other substances known to the State of California to cause cancer. Wood products also emit chemicals known to the State of California to cause birth defects or other reproductive harm. (California Health and Safety Code Section 56).
13. In addition to other health hazards, dust from wood and other materials is flammable. Do not operate welding, wood burning, smelting, soldering or other high-heat tools on the AutoRoute™ table or vicinity.
14. Do not operate this machine while tired or under the influence of drugs, alcohol or any medication.

Electrical

15. Make certain the switch is in the OFF position before connecting the machine to the power supply.
16. Make certain the machine is properly grounded and the circuit is protected with a fuse or circuit breaker in accordance with local codes. Install a separate circuit if necessary, to limit power loss when multiple machines in your shop are operating simultaneously. If necessary, place a cover on the outlet to prevent accidental disconnection.
17. Perform all machine adjustments or maintenance with the machine unplugged from the power source.
18. Follow effective lockout procedures to reduce the risk from high voltage wires and components and prevent intentional bypassing of safety controls and accidental operation.
19. Don't use in a damp or wet location, or expose to rain, fog or snow.
20. Keep the electrical cord away from sharp edges, heat or moving parts, and do not store materials on top of it. Position the cord so it will not become a tripping hazard.
21. While the use of an extension cord is discouraged, it is recognized that the wiring layout of the shop may not allow the placement of the AutoRoute™ directly next to an outlet. If it is necessary to use an extension cord, make sure the extension cord is in good condition, heavy enough to carry the current requirements, and installed to prevent a tripping hazard. An undersized cord will cause a reduction in voltage resulting in loss of power and overheating which may result in fire or electrical shock.

Other Safeguards

22. Remove and store adjusting keys and wrenches before turning on the power. If necessary, for visibility, apply safety markings to adjusting wrenches and keys.
23. Install safety guards consistent with general shop safety practices. Keep safety guards in place at all times when the machine is in use. If removed for maintenance purposes, use extreme caution and replace the guards immediately after completion of maintenance.
24. Check damaged parts immediately. Before further use of the machine, a guard or other part that is damaged should be carefully checked to determine that it will operate properly and perform its intended function.
25. Keep visitors a safe distance from the work area. Keep children away.

26. Control liquids in your shop to limit the possibility of spillage that can damage the AutoRoute™ which can cause damage or personal injury from electric shock or fire. Be careful with storage and use of cleaning fluids, finishes and solvents. Never use the table to apply or dry finishes.

Maintenance

27. Establish a weekly and monthly maintenance checklist and follow it diligently.
28. Routine maintenance should include periodic checks for alignment of moving parts, looseness or binding of moving parts, worn or bare wires, breakage of parts, skewed mounting and any other conditions that may affect its operation or cause injury. Analyze breakage or damage to determine the cause and take appropriate remedial action.
29. Do not operate the AutoRoute™ if a component of the control system is damaged. It should be properly repaired or replaced before use.
30. Follow instructions for lubricating and changing accessories.
31. Store maintenance tools and supplies nearby, consistent with shop maintenance practices and resources.

Operational Practice

32. Never leave the machine running unattended. Always be in close reach of the emergency stop button.
33. Turn the power off and do not leave the machine until it comes to a complete stop.
34. Avoid pinch points and entanglement hazards. Keep hands and clothing away from the ball screws, thrust bearings, gantry, guide rails and rotating cutting tool while in operation.
35. Use the right tool at the correct speed and feed rate. Do not force a tool or attachment to do a job for which it was not designed. The right tool will do the job better and more safely.
36. Do not touch a cutting tool immediately after use. It will be hot and may cause skin burns. Exercise caution when handling the collet and spindle nut if the cutting tool is hot. Keep a heavy glove or oven mitt on hand for the purpose.
37. Do not lay a hot cutting tool on its side. Create a rack for cooling off hot cutting tools.
38. Use recommended accessories; improper accessories may be hazardous.
39. Do not use dull, gummy, or damaged cutting tools. Keep bits and other cutting tools clean and sharp for best and safest performance.
40. Turn off the machine before cleaning. Use a vacuum, brush or compressed air to remove chips or debris. Do not use hands.
41. Do not climb or stand on the machine. Serious personal injury and costly damage could occur if the machine tips over or the gantry is dislodged.
42. Remove loose items and unnecessary work pieces from the table before starting the machine.
43. Plan tool paths to make multiple passes rather than to take off a large amount of material at one time. This will reduce mechanical stress and heat on cutting tools.
44. Always secure a work piece to the spoil board using clamps, vacuum, or double-sided tape. If the work piece is mounted in a jig, ensure that the fixture is securely held to the table. Never hold a work piece down by hand while operating.
45. Inspect the material of your work piece to detect any defects that may result in ejection of large pieces of scrap.
46. Make sure the work piece is free from nails, hardware, or other foreign objects.
47. After installing a cutting tool, make sure the collet is securely tightened. An unsecured cutting tool may fly loose from the collet and cause injury. Be sure that the adjusting wrenches have been removed and are secured before turning on the power.

Emergency Switch

To avoid accidental or unintended use by young children or others not qualified to use the tool, a padlock may not be required.

WARNING: FOR YOUR OWN SAFETY READ INSTRUCTION MANUAL BEFORE OPERATING TOOL:

To lock out using an Emergency switch on the **AR8 Elite**:

1. Open the padlock.
2. Insert through hole in the Emergency switch (need depress this button).
3. Close the padlock.
4. Place the KEY in a safe place out of the reach of children.

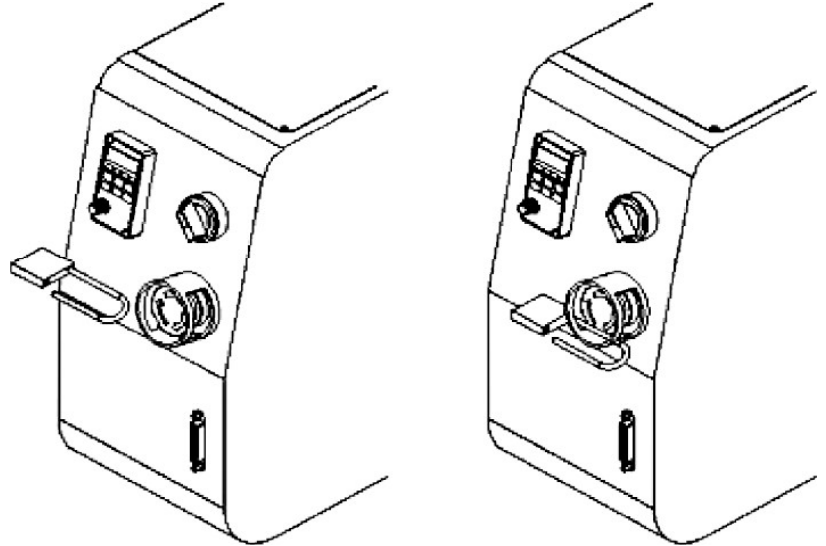

To lock out using the Emergency switch on the **AR16 Elite**.

1. Depress the Emergency Stop button.
2. Rotate the button counterclockwise to remove.
3. Store button in safe location (machine remains inoperable until unlocked).
4. To unlock, reinsert button and rotate clockwise until the Emergency Stop is released.



State of California Prop 65 Disclaimer

WARNING: This product can expose you to chemicals, including dust from wood, wood byproducts, and a variety of plastics, which are known to the state of California to cause cancer.

For more information, please go to:
www.p65warnings.ca.gov

Table of Contents

Section	Page
1. Safety Information	2
2. Emergency Switch Padlock	5
3. Router specifications	7
4. Glossary of terms	8
5. Setup and Assembly	
5.1. Packaging Contents	11
5.2. Stand assembly	12
5.3. Installing Router	13
5.4. Finishing Machine Assembly	14
6. Electrical Connections	15
7. Post Processor Information	16
8. Operations	
8.1. Controller Intro	17
8.2. Operating procedure	18
8.3. HOME Position	18
8.4. Moving Router (Spindle Head)	19
8.5. Setting Work Origin	20
8.6. Programming Additional Origins	22
8.7. Returning to Programmed Origins	22
8.8. Setting Spindle RPM	23
8.9. Processing a File	23
8.9.1. Copying Files to internal Memory	23
8.9.2. Deleting Internal Files	24
8.9.3. Speed Scale Adjustment	24
8.9.4. Pausing During a Toolpath	24
8.9.5. Part Work	25
9. User Defined Controller Settings	26
9.1. Editing User Defined Settings	28
10. Maintenance	
11. Troubleshooting	30
11.1. Error Messages	34
11.2. Alarm Codes	43

Specifications

AutoRoute:		8 Elite	16 Elite
X Axis Travel	24" (610mm)	•	
	48" (1210mm)		•
Y Axis Travel	48" (1220mm)	•	•
Z Axis Travel	8" (200mm)	•	•
Table Work Area	28.5" x 63" (724mm x 1600mm)	•	
	51" x 69" (1300mm x 1750mm)		•
Collet	ER-20	•	•
Collet Chuck	1/4" and 1/2" Included	•	•
High Speed Spindle	3 HP 2.2kW/7.5A Electro Spindle	•	•
Spindle Speed	0~24000 RPM	•	•
Rapid Feed Rate	320 IPM (8 M/min)	•	•
Precision Linear Guide Rails	X/Y/Z Axis	•	•
Precision Ball Screw	X/Y/Z Axis	•	•
Power Requirements	220V, 50~60 Hz, 15A Single Phase	•	•
Working Table	High Rigidity Interlocking Aluminum	•	•
	Integrated MDF Spoil Board	•	•
Gantry Bridge	High Rigidity Aluminum Extrusion	•	•
Gantry Support	Gravity Cast Aluminum Alloy	•	•
Gantry Clearance	8" (200mm)	•	•
Machine Base	Welded Structural Steel Frame	•	•
Machine Footprint	34.5" x 63 (875mm x 1600mm)	•	
	60" x 75" (1525mm x 1900mm)		•
Required Floor Space	38" x 82" (965mm x 2000mm)	•	
	70" x 120" (1775mm x 3000mm)		•
Max. Machine Height	62" (1575mm)	•	
	58" (1475mm)		•
Machine Weight	764lbs (347kg)	•	
	1420lbs (645kg)		•
Tool Touch Off Puck	Standard Accessory	•	•
Integrated Liquid Cooling System	Standard Accessory	•	•
Controller ¹	RichAuto B58 DSP	•	•

¹• Supports the standard G code, PLT format instructions; supports domestic and international mainstream CAM software, such as: Type3, Art cam, UG, Pro / E, Master CAM, Cimatron, Wentai etc.

• Comes with USB communications port, file transfer efficiency can be directly read U disk, card reader file, Plug and Play.

Glossary

4th Axis – An accessory that enables the CNC to operate as a lathe.

Axis – Direction of movement. On a three-axis machine: X (left-right), Y (front-back) & Z (up-down).

Array Work – Division of the machine work surface into square or rectangular work spaces so that the toolpath can be ran in each space to produce several identical profiles.

Ball End (Ball Nose) – A cutting tool that has a rounded cutting arc, where the arc diameter is equal to the cutting diameter.

Ball-screw – Drive system component. The ball-screw is rotated by the stepper motor and provided the means for moving the gantry and spindle along the axes.

Bed – The Bed of the CNC consists of a welded steel frame and an extruded aluminum table top, tongue and groove table top with integrated T-slots.

CAD – Computer aided design using software to assist in designs

CAM – Computer aided manufacturing using software to define toolpaths and assist in manufacturing processes.

Chip Load – Chip load is the measure of the thickness of a chip a cutter will cut.

CNC – Computer numerical control

Climb Cut – Refers to the relationship of the cutting tool rotation to the direction of feed. A climb cut deflects the cutting away from the cut, with the direction of the feed.

Collet – A metal collar that holds the cutting tool within a spindle nut.

Conventional Cut – Refers to the relationship of the cutting tool rotation to the direction of feed. A conventional cut deflects the toward the cut, against the direction of the feed.

Compression Bit – A cutting tool with a combination of up and down shear cutting edges. Typically used for cutting laminate material to prevent tear-out on both sides of the sheet.

Deflection – Tool deflection occurs when the spindle speed and feed rate exert sufficient force to deflect the cutting tool. Deflection leads to excessive wear and chatter which can shorten tool life and will leave unwanted tooling marks on the material.

Down-Shear Bit – A cutting tool whose edges carve downward on the face of the toolpath. Reduces the potential for tear-out but requires a slower feed-rate.

Drag Knife – A cutting tool that holds a razor or knife blade used to cut and inscribe material. Used with spindle or router motors turned off, and freely spins as it follows the direction of the tool-path.

Dust Shoe – An accessory which aids in dust collection by limiting the spread of dust and debris by channeling the air flow through an attached dust collection system.

End-Mill – A cutting tool with a straight end, typically with a spiral flute(s). It creates a channel with a flat bottom perpendicular to the sides.

Feed and Speed – A combination of factors that must be set to control the work performed by the cutting tool.

Feed-rate – The speed at which the cutting tool moves along a work piece.

Flute Length – The length of the cutting portion on a router bit or cutting tool.

Flutes – The cutting edges or inserts of a router bit or cutting tool.

Finish Cut – A 3D tool-path that reduces or eliminates the irregular contours left by the rough cut.

Form Bit – A bit that carves a standard profile such as a round over, ogee or similar contours.

Gantry – The frame structure that straddles the bed and carries the spindle. It moves on guide rails along the length of the bed and is driven by the ball-screw system.

Gantry Bridge – The part of the gantry that lies between the upright towers. The upper bridge carries the spindle and cooling system. The lower bridge supports the weight of the gantry and affixes directly to the Y axis ball-screw.

Gantry Upright (Towers) – Parts of the gantry that extend upward, supporting the upper gantry bridge.

G-Code – A machine language that uses axis points and commands which the machine uses to move and perform functions.

Grid – The minimal movement units of the router. The router head automatically moves to the next grid position when the directional button is toggled in either continuous or step mode.

HHC – The handheld controller component of the control system.

Hold-down – A clamp or other such device used to firmly hold a workpiece or fixture to the table. Includes clamps, double-sided tape, vacuum pods and others.

Home Position – Mechanical point set using magnetic limit switches.

MCM – Machine Constant Parameters, allow manufacturer to define certain machine constants to match specifications of the equipment and machining requirements.

Origin – User designated zero point for the work piece. From which the router will reference the positioning of all cutting.

Plunge – The distance on the Z axis that the spindle and cutting tool moves toward, into, or along the material.

Plunge Rate – The speed of descent of the spindle on the Z axis.

Pocket Tool-path – A toolpath that creates a cavity in the horizontal surface of a work piece.

Positioning Dial – Small dial, found on the lower right portion of the controller which is used for fine movement of an axis using a present unit of measurement. Units are selected by using the Function F2 Key when on the Jog Screen and can be cycled between MPGx100(0.1mm), MPGx10(0.01mm) and MPGx1(0.001mm).

Post Processor – A software function that enables the CAD/CAM application to format G-Code enabling the control system of a CNC to follow the designated toolpaths.

Profile Tool-path – A tool paths that cuts along the profile of a set of vectors. Typically used to cut out the shape of a design.

Proximity Switch – A magnetic limit switch that is used to find the HOME position.

Rough Cut – A 3D toolpath where the initial cut is designed to remove unwanted material, leaving a rough contour.

Selection Dial – Small dial, found on the lower left portion of the controller which is used to select one of several sets of different operations.

Soft Limits – Limits on movement availability. Imposed by the workspace boundaries and based on controller settings and the location of HOME. An “out of soft limits error” implies that based on the positioning of the workpiece, there is not enough room to move in a designated direction.

Speed Scale – Allows for the reduction of the feed-rate at the beginning of a toolpath to reduce the stress on a cutting tool as it first contacts the material.

Spindle Speed – Rotational speed of cutting tool (RPM).

Step Down – Distance in Z-axis that the cutting tool plunges into the material.

Step-over – The amount the cutting tool moves away from the previous cutting path as it routes the new path.

Surfacing – The process of leveling the surface of the spoil boards so that they are perpendicular to the spindle.

Tool-path – User defined route which the cutter follows to machine a workpiece.

Touch-Off Puck – A device used to set the zero point (Origin) for the Z axis.

Up-Shear Bit – A cutting tool whose edges curve upward along the face of the toolpath. Increases the potential for tear-out but allows for a slightly higher feed-rate.

Working Envelope – The three-dimensional area that the spindle can travel within while cutting or milling.

Setup and Assembly

Failure to read and understand all the assembly and setup instructions before attempting assembly may result in serious injury.

Packaging contents for the Axiom Precision Stand. (AR8 Elite Only)

- 2-Stand upright (front & back)
- 2-Cross braces
- 1-Lower shelf plate
- 1-Stand hardware package

Hardware package contains:

- 4-Swivel casters
- 4-Leveling Feet
- 4-hex nuts
- 16-Hex bolts (M8x25)
- 16-Lock washers (M8)
- 16-Flat washer (M8)
- 16-Hex bolts (M6x12)
- 16-Lock washer (M6)
- 16-Flat washer (M6)
- 1-Controller hook
- 2-Machine screws (M4x6)
- 4-Small rubber pads

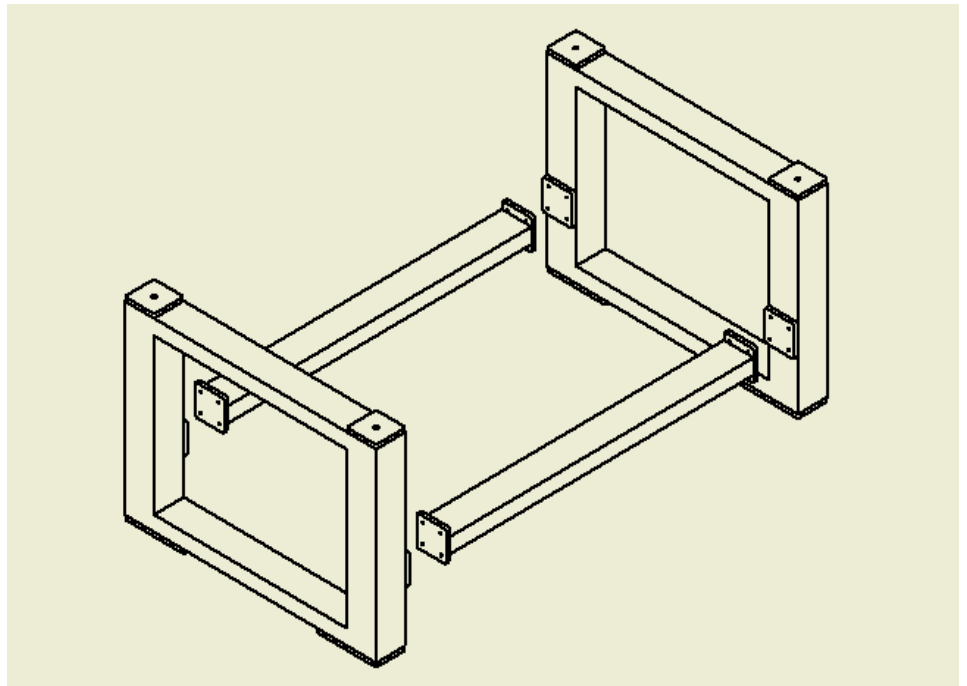

Remove all contents from shipping boxes. Do not discard carton or packing material until assembly is complete. Accessories commonly ship inside machine or stand packaging and can be easily overlooked.

Tools required for assembly:

- #2 Philips-Screwdriver
- 10mm, 13mm and 17mm sockets and socket wrench
- 24mm open-end wrench
- 2mm and 3mm Allen key
- Level

Packaging contents for Axiom Precision CNC machines:

- 1-Router table assembly
- 1-Electrical control box
- 1-Hust Industrial handheld controller
- 1-Controller cable
- 1-Tool touch-off puck
- 1-USB Storage device
- 2-Collet wrenches
- 1-1/4" ER-20 Collet
- 1-1/2" ER-20 Collet
- 4-Rubber bushings (AR8 Model Only)
- 4-Hex Bolts (M17x45) (AR8 Model Only)
- 4-Washers (M17) (AR8 Model Only)
- 4-6 Plastic Caps (Cover Stand Mounting Bolts)
- 1-2mm Allen Key

Assembling Stand (AR8 Elite Model Only):

Assembly for the AR8 Elite series machines is the same as Pro+/ Basic machines. The difference being that the stand and toolbox are included as part of the Elite machine.

- 1- Thread a (1) loose hex-nut onto each of the (4) leveling feet.
- 2- Turn the square stand uprights upside down. Do this on top of the cardboard packaging to prevent scratching.
 - a. Install the (4) leveling feet and (4) swivel casters using (1) M6 hex bolt, (1) M6 lock washer, and (1) M6 flat washer for each caster. Tighten all the caster hardware securely. The leveling feet can be adjusted later.
 - b. Rotate uprights so the cross-brace mounting plates are facing each other. Separate the uprights far enough that the braces can fit between them.
 - c. Align the cross-braces between the uprights and bolt the mounting flanges to the plates using (4) M8 hex bolt, (4) lock washers and (4) flat washers for each side.

As seen in the diagram above, the braces should be rotated correctly for the tool-box and shelf to sit at the correct height. Braces should be mounted so that the top and bottom are the larger flat surfaces



- 6- With assistance, the stand can now be flipped over onto the casters and leveling feet.
- 7- Flip the Shelf upside down and stick (1) of the rubber pads on each corner of the shelf flange.
 - a. Install shelf between the braces on the stand, all the way towards the rear.
 - b. The small rubber pads should now be between the flange and the top surface of the brace. This will help prevent unwanted movement and scratching.
 - c. The DSP hook for the controller should be installed on the front right side of the stand.



Installing the Toolbox:

The toolbox will sit to the front of the stand, so be sure to orient the shelf towards the rear to serve as storage.

- d. Turn the tool-box upside down. Install (1) of each hanger on either side of the toolbox using the installed threaded inserts and (2) 3mm cap-screw each.
- e. Insert the toolbox into the stand, from the top. The hangers will with snugly between the braces on either side of the toolbox.
- f. The front can be slid forward to rest within the opening on the stand upright.



Installing the router table on the Stand:

The CNC router table assembly is heavy. Please use a secure means and use caution when lifting onto the stand.

To avoid damage, be careful to never lift the router by the gantry.

- 1- If using a forklift, keep forks under the steel frame to avoid damaging the wiring and mechanics of the machine.
 - a. Place a scrap piece of lumber beneath the router assembly and carefully slide forks beneath the steel base.

Make sure the forks extend through to the other side of the machine for safe lifting.

- 2- Position router over the stand and align holes on router mounting flanges and stand uprights. Being careful to make sure the stand is properly oriented with the machine front.

- 3- Place (1) rubber bushing over the holes in the stand. Lower the machine to sit on the bushings.
 - a. Attach the machine to the stand using (1) M10 Hex bolt, (1) washer at each corner.

- b. Insert the bolt/washer through the machine base/mounting flange and the rubber bushing.
 - c. Thread the bolt loosely into the stand mounting holes. **Do not tighten until all bolts have been threaded.**
 - d. Remove forklift and tighten bolts evenly.



- 4- Place level on the router table, then level the assembled machine by adjusting the leveling feet. Be sure to level the machine in all directions.



Finishing machine assembly:

With the machine mounted on the stand, or safely on a secure work surface if a stand was not acquired, now it's time to begin finishing the setup.

- 1- Insert the control box into the front right cavity of the toolbox.
 - a. Power and communication cables will run through the lower hole in the back of the toolbox.

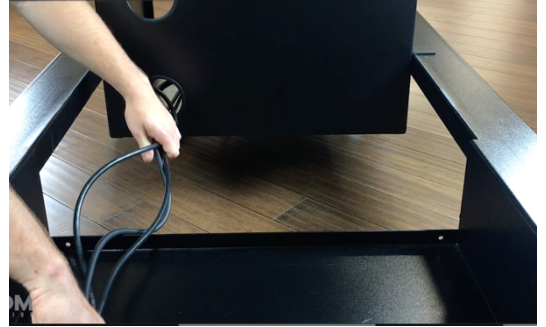

- 2- Insert the cable connectors into their corresponding female receptacles and twist the collar to tighten. The receptacles are keyed, so the plugs will only insert one way.

- 3- Be sure to position the electrical cord through the back of the stand safely, so it will not be damaged by the castors or become a tripping hazard.

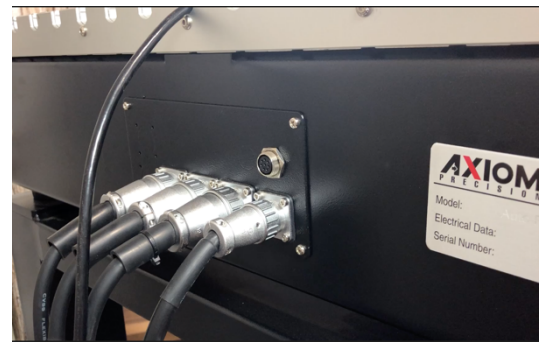

- 4- Attach the controller cable to the front of the control box. **Be careful to not overtighten the screws.**
 - a. Connect the hand-held controller securely to the opposite cable end.



Electrical Connections



All Electrical connections must be performed by a qualified electrical and follow any local codes and ordinances. Failure to comply may result in serious injury.

Electrical connections that are improperly installed or are outside operational specifications may cause machine damage and void any warranties that are in place.

This machine is rated for 220V +/-10% having an operational range of 200-240V. The machines come pre-wired with a **NEMA 6-20** plug for use on a circuit with a grounded outlet as pictured. It is recommended that these machines be connected to a dedicated 15-amp circuit.

If the machine must be reconnected for use with a different type of electric circuit, the connection must be done by qualified person(s) and must comply with all local codes and ordinances.



Grounding Instructions:

Axiom CNC machines must be grounded. This grounding provides a path of least resistance for electrical current, which during a malfunction will reduce the risk of electrical shock.

All Axiom machines are equipped with an electrical cord with grounding conductor and plug. The plug must be used with a matching outlet that is properly installed and grounded in accordance with local codes and ordinances.

These plugs must not be modified, if a matching outlet is need, one must be installed by a qualified electrician.

Improper installation may result in electrical shock.



If grounding instructions are not completely understood or if in doubt as to whether the machine is properly grounded, a qualified electrician should be consulted.

Extension Cords:

The use of extension cords should be discouraged. It is recommended to place the machines as near to the power source as possible.

If an extension cord is necessary, make sure any cord used is in good conditions. Worn or damaged cords should be replaced immediately.

When using an extension cord, be sure to use one that is heavy enough to carry the required current and use only 3-wire extension cords that feature the correct 3-prong grounding plugs and 3-pole receptacles.

An undersized cord will cause a drop-in line voltage resulting in loss of power, overheating and runs the risk of fire.

It is recommended that if an extension cord must be used, it be a 10-12 gauge grounded-three wire cord of no more than 8-10 feet.

Important Post Processor Info:

With the purchase of a new Axiom Precision Elite Model CNC using a RichAuto DSP controller, there will be no need for a new post processor for the VCarve or Aspire software.

Customers will find an Axiom HHC CNC (mm) *.mmg post processor already installed within the software...if needed, please visit www.axiomprecision.com/post to download any the Axiom supported post processors.

*With any CNC machine it is important when saving tool-path files to use the correct post processor and units for the machine being operated.

If any trouble is found with the required post processors, please contact the Technical Services Department of Axiom Tool Group with the contact information listed below:

Phone 844-642-4902

Email: support@axiomtoolgroup.com

Fusion 360 Post Processors:

With the addition of the new RichAuto B58 DSP controller, the Axiom Elite machines can no more easily be supported by additional post processors used within a number of alternative programs.

Users interested in using Autodesk's Fusion 360 program will find that the [RS274.cps](#) post is the most widely recommended.

Operations

Before getting started with the machine, it is recommended to become familiar with the handheld controller for operation of the machine, setting up a job and processing a file.

Controller:

Toolpaths, that are created in the design software are communicated to the CNC router through the handheld controller. On the Elite series machines, this is done through the RichAuto B58 DSP controller.

Processing toolpaths or jobs is performed either by using a USB Flash drive (USB2.0 of 8GB or smaller FAT 32) or by accessing files stored in the controller internal memory. (512MB)

Internal memory is recommended for jobs of 1 hour run time or longer, and any files that will be used frequently.

USB flash drives should be USB2.0 8GB or smaller, formatted to FAT32



The RichAuto B58 controller keypad, which is seen here uses either;

Single touch functions where buttons may perform one of many single tasks or if held down, will perform a task continuously (such as machine movement).

Combination functions, where two keys are pressed at the same time.

Saving a file to internal memory:

After the homing procedure has been completed, from the main screen on the controller press the MENU button. Using the X+/X- buttons to scroll highlight OPERATE FILE and press the **ORIGIN/OK** button.

The option to Copy or Delete a file should be displayed. Highlight **COPY FILE** and press the **ORIGIN/OK** button.

The next screen displayed will ask where you would like to copy the file from. At this point you will select from the **UDISK**. Your controller should display a list of files on you flash drive from there simply highlight the file you wish to copy and press **ORIGIN/OK**. A small loading screen will appear. At this point your file will have been successfully saved to the internal memory on the controller.



Operating Procedure:

Machine operations may be done several ways; either through the controller keypad or through the toolpath files which can be operated by the controller from the USB (Udisk) or saved to internal memory for easier access.

Before performing an operation:

- 1- Make sure machine stand leveling feet (if available) have been lowered to prevent the machine from moving.
- 2- Ensure that the workpiece is secured to the table which can be done using any of the following:
 - a. Clamps
 - b. Fixtures
 - c. Double sided tape
- 3- Turn on the machine by rotating the green switch located on the white control box to the right. The controller display should light, displaying the loading screen.
 - a. The emergency stop button may need released if it has been used.

Once done loading, a HOME operation must be performed before any other function.

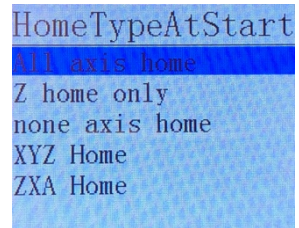

HOME Position:

When turning on the machine, once the controller has finished loading, the following message will be displayed:

At this point, the controller can be used to scroll up and down the list using the **Y+/Y-** buttons. The first option of "All axis home" should be selected using the **REF/OK (ORIGIN/OK)** button.

Home position is determined by a set of magnetic proximity sensors, one of which can be found on each axis. These sensors can be calibrated, however, their overall position should not change.

During a HOME operation the following will occur:

- 1- First the Z axis will raise to the top of the axis travel.
- 2- Then the X & Y axes will travel, simultaneously, to the front left corner of the machine.
- 3- When complete the controller will display the workpiece coordinate screen.

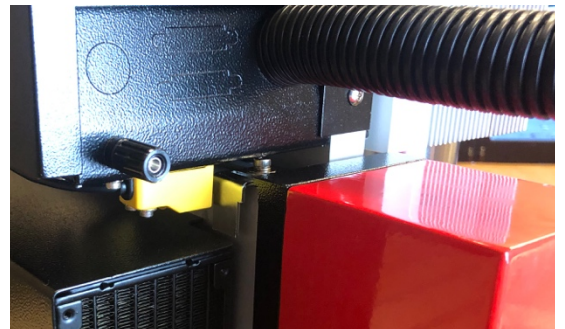

The workpiece coordinate screen will display the coordinate state the controller is currently using and the position of the spindle in relation to the programmed **Origin** (0,0 point).

It is important that a **HOME** operation is performed at every start-up to ensure that the limit switches and internal software settings are properly working. All machine movements are software driven and based upon the **HOME** position.

At any time during a machine operation, the HOME operation can be selected to run from the controller using the ZRN (HOME) button. (Must be done from the main coordinate screen)

Selecting the **ZRN (HOME)** button will display the **HOME Type** menu where several options are available, such as:

- 1- Home all
- 2- Home X (X axis only)
- 3- Home Y (Y axis only)
- 4- Home Z (Z axis only)

Moving Router (Spindle) head:

Movement of the router or spindle head can be done manually in one of several ways. All of which can be toggled between by using the **MODE** button. (Chosen mode will be displayed on the lower right portion of the controller screen)

Continuous and **Step** mode both use internal grid settings (minimum movement feed) to aid in accuracy. This default has two settings depending on the movement speed mode selected (**L SP** or **F SP**). This movement speed mode can also be seen on the controllers coordinate screen display, third row down on the far right.

To switch between these two modes, simply use the **Fast/Slow** button.

When in either Continuous or Step mode, the machine will move to the next nearest grid distance when the button is toggled or pressed just once. See below:

L SP-Slow speed- has a grid of 0.1mm for positional movements and a continuous speed that is set at 1500mm/min default.

F SP-Fast speed-has a grid of 0.5mm for positional movements and a continuous speed that is set at 2500mm/min default.

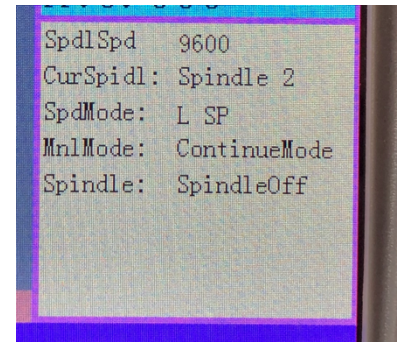

- 1- **Continuous mode:** Hold down any axis directional button, i.e. **X+/-, Y+/-, Z+/-, A+/-** and that axis will move until the button is released.
 - a. The controller will display the location of the router in relation the current **Origin** as it moves.
 - b. During the first 0.5 sec, the button is held down the machine will operate as if in step mode and move to the nearest grid at a lower speed.
 - c. While in continuous mode, the machine will always stop on a grid position.
- 2- **Step mode:** Tap (toggle) any of the directional buttons, i.e. **X+/-, Y+/-, Z+/-, A+/-** to move the router head in grid-based increments. Useful for precise placement of coordinates and tooling.
 - a. The movement speed is defaulted at one grid distance per 0.5 sec.
 - b. **Slow speed (L SP)** default is 0.1mm grid
 - c. **Fast speed (F SP)** default is 0.5mm grid
- 3- **Distance mode:** Allows the input of a set distance to which the router will move. To use the distance mode:
 - a. Press **MODE**, to cycle through until it a separate **Distance mode** box appears.
 - i. A numerical distance will be displayed.
 - b. Enter the new desired distance and press **OK**.
 - i. Display will now continue to show Distance mode within the lower right portion of the screen, temporarily.
 - c. Tap any of the directional buttons to move the router head the programmed distance in that direction.
 - i. i.e. Tapping the Y+ button will move the gantry along the Y axis in the + direction the specified distance.

Setting Work Origin:

Creating an **Origin** will establish a zero point or reference point from which the machine will perform the cutting process set in the toolpath.

The **Origin** should match the zero point (datum) of the uploaded toolpath created in the design software.

An Origin for both the X & Y axes and the Z axis need to be set before beginning operation of a 3-Axis file. Failure to set both Origins may result in damage to the machine or the cutting tool.

To set the **Origin**:

- 1- Make sure the collet is properly inserted into the collet-nut before being threaded onto the machine. Then insert the tooling into the collet and tighten using the included wrenches.
 - a. Use only **ER-20** collets, of the correct size matching the shaft diameter of the selecting tooling.
- 2- Move the spindle or router to the desired location using the X and Y directional buttons.
 - a. Remember that the controller can be switched between movement speeds using the **F SP & L SP** settings. **Step** mode or grid movements can be used to place the bit more accurately for the **Origin** placement.
 - b. This location is typically one of the corners of the work material or the exact center point.
- 3- Press **X/Y-0** to set the **Origin** for the X and Y axes.
 - a. This will instantly change the displayed coordinates of the X and Y axes to 0.00
- 4- There are several ways to set the **Z-0** or **Z-axis Origin**, which may change depending on the material or router bit that is being used.

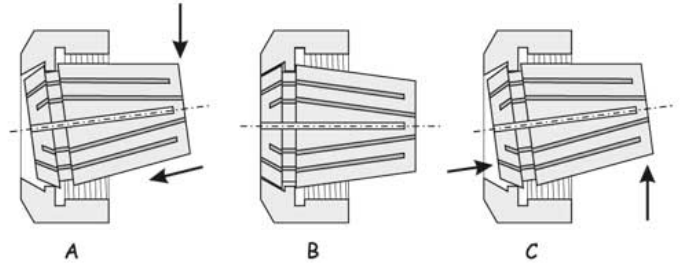

- a. Using the provided tool touch-off device. Which plugs into the back of the gantry on **HOME** side. (**AR8 Elite**).

***Plug placement for the AR16 Elite can be found on the left side of the upper Z-Axis cover.**

- i. Place the device on top of the material, centered under the cutting tool.

It is recommended to use the top of the material, however, be sure to select this in the design software when setting up the material parameters.

- ii. With material that is not uniform in thickness, the top of the spoil board may be used for the tool touch-off device placement.

Again, be sure that the selection in the software matches the chosen location of the device.

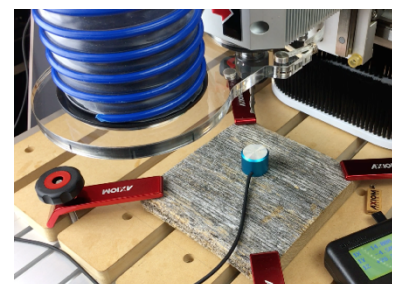
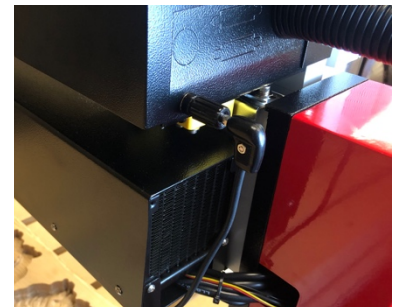

- b. Once the device is in place and centered under the bit, press the **Tool Set** button to start the procedure. The router head will then slowly lower until the bit contacts the device and then return to a raised position. The **Z-axis Origin** is now programmed.
 - i. The bit may make contact, raise just slightly and slowly lower again to calibrate. This is a normal occurrence and may happen randomly.

- c. More fragile bits may require that the **Z-Axis Origin** be set manually without the use of the touch-off device to prevent the tooling from breaking. To set the **Z-0** point manually:
 - i. Place the controller into **Step** mode, and slowly lower the router head while rotating the tooling by hand until resistance is felt as the bit contacts the workpiece.
 - ii. For more precise placement, use a thin piece of paper. Slide the paper back and forth on the material until drag is felt as the tooling presses against the paper and material.
 - iii. Once lowered to the desired location, use the **Z/C-0 (Z/A-0)** button to program the Z-axis origin.
 - iv. When pressed, a secondary screen will appear.

Select either **Clear Z** (sets the Z-0 location) or **Clear C (A)** *used with the 4th Axis.



It is recommended that the Z-axis Origin be set relative to the top of the work material to reduce risk of cutting into the sacrificial tabletop.

Once the **Origin** is completely set, the coordinate screen will reflect this information by showing both the X and Y axes now being set to 0.00. The Z-axis will have raised to the programmed safe height after touching the puck and will now reflect that distance.

Remember that the Z-0 location is the surface of either the material or the spoil board, in which the controller should only read zero along the Z axis when the bit is touching that surface.

NOTE: When the machine is restarted, a HOME operation must be done to reset that reference point. However, the last programmed Origin (always programmed in reference to HOME) is still stored in memory. Simply press the OK button and the machine will return to this location.

Programming Additional Origins:

The RichAuto controller allows multiple offsets (**Origins**) to be programmed.

The Workpiece # found in the upper right portion of the controller screen represents the coordinate state presently in use. Each coordinate state will have a unique programmed **Origin** for each axis.

To switch between coordinate states, press MENU & (any number 1-9). The coordinate screen will change and show that set of coordinates.

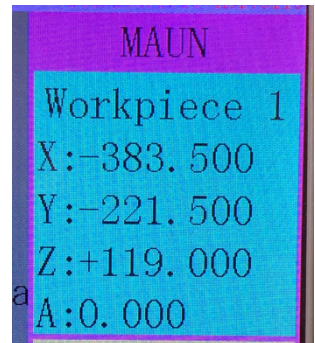

This feature is useful when creating fixtures or when separating the machine surface into quadrants for specific tasks.

For example: If using a 48" work area, to perform jobs that are less than 24" in size. The surface can be set up as two 24" areas. Using the same HOME.

In the Menu + 1 area (coordinate state #1), the **Origin** would be set for the first piece of material.

In the Menu +2 area (coordinate state #2), the **Origin** would be set for the second piece of material.

The materials can be loaded onto the machine, preferably using a fixture for ease of referencing. The first job can be performed from the #1 state. Then the controller can be switched to the #2 state, and the second piece of material can be machined.

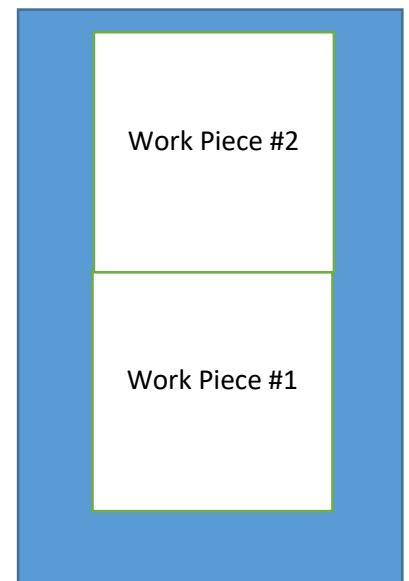

Setting Spindle RPM:

The Elite machines are equipped with an on-board VFD inverter. This device which can be found in the machine electronic case, allows for high frequency control of the Spindle RPM.

The current RPM (labeled as SpdlSpd) is displayed in the lower right portion of the screen display.

For RPM Adjustment, press the **SPINDLE** button and the **S+%** or **S-%** buttons together. To increase (**S+%**) or decrease (**S-%**) in 1200 RPM intervals.

This can be adjusted at any time. Included during a machine operation. Allowing RPM to be dialed in dynamically as needed.

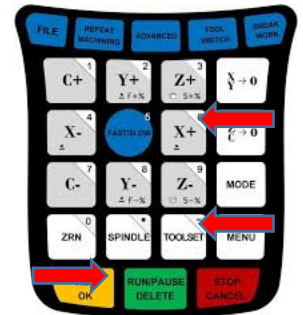
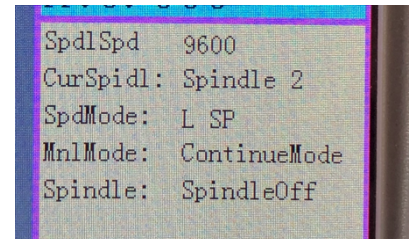

Processing a File: **Selecting and Running a Toolpath**

Once the **Origin** is placed (on all axes) and the RPM is set, the file can be selected, and machining operation can begin.

*Once files are saved to the U-disk it is recommended that the PC-Eject feature is used to safely remove the drive from the computer.

To begin (From the coordinate screen):

- 1- Press the **File** button located in the upper left portion of the keypad to activate the Select Work File menu.
 - a. Use the **Y+/Y-** buttons to scroll up or down the list.
 - b. Highlight the file location and press **OK** to select.
- 2- The files in that directory will then be displayed.
 - a. Use the **Y+/Y-** buttons to scroll up or down the list.
 - b. Highlight the desired tool-path (.mmg filetype), press **OK** to select
- 3- The controller will return to the main coordinate screen.

Where the selected file will be listed at the bottom left corner of the screen.
- 4- When ready, press the **RUN/Pause/Delete** button to show the **Set Work Parameters** screen.
 - a. Work Speed: Similar to feed-rate. This will be ignored as the controller is setup by default to take this feed-rate setting from the software. **Settings can be changed allowing feed-rate to be set here.**
 - b. Fast Speed: Shuttle speed. This is the speed the machine will travel between cutting locations.
 - c. Speed Scale: A percentage of the feed-rate. (See **Speed Scale Adjustment**)
- 5- Press **OK** to begin the tool-path operation.
 - a. After a short count-down (4sec) during which the spindle will come up to speed, the file will begin.

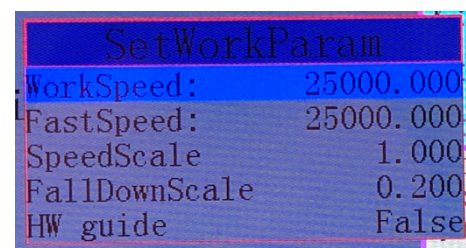
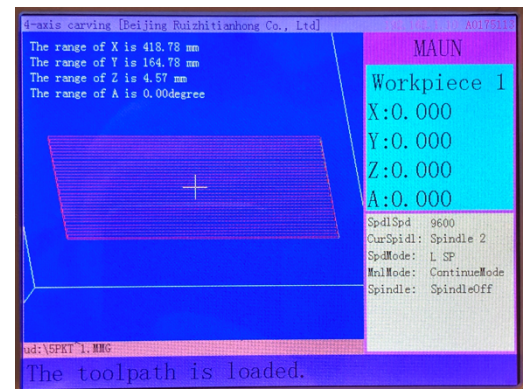
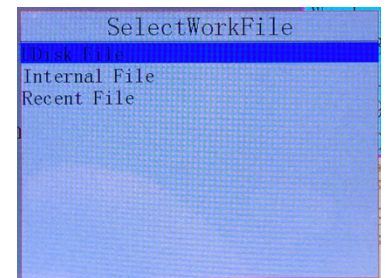

Speed Scale Adjustment:

The **Speed Scale** (percentage of the feed-rate programmed within the software) is displayed before a toolpath file is set to begin. This can be changed both before the file begins (during the **Set Work Parameters** screen) and while the toolpath is in operation. To adjust this parameter:

- 1- Before the toolpath begins - While the file **Set Work Parameters** screen is being displayed, highlight the **Speed Scale** setting.
 - a. Use the **Delete** button to select and remove the original parameter. Enter the new parameter and press **OK** to select. **Must be 0.1 (10%) through 1.0 (100%) in 0.1 increments.**
- 2- While the toolpath is operating – The **Y+/-** buttons can be used to increase or decrease the **Speed Scale** in the above-mentioned default 0.1 (10%) increments.
 - a. Cannot exceed 1.0 (100%) of the feed-rate programmed in the software.

Pausing During Tool-path Operation:

A file that is in operation, otherwise known as a job, can be paused. While **Paused**, some changes can be enacted. This function should only be used for very brief pauses to adjust settings, such as bit height or position.

To Pause a job:

- 1- Press the **Run/Pause** button during operation.
 - a. The machine movement will immediately stop.
 - b. **Spindle will remain active!!**
- 2- While the machine is **Paused**, the bit position can be adjusted in any direction.
 - a. It is recommended this be done in **Step** mode, and in **Slow** speed (**LSP**).
- 3- After making the adjustments, press **Run/Pause** to continue the file operation.
 - a. The display will show a **Restore Position?** prompt.
 - i. Press **OK** to resume using the modified settings.
 - ii. Press **Cancel** to resume using the previous settings.

Be advised, changes that are made will only affect the toolpath in operation.

Setting a Breakpoint:

Like the **Pause** function, a Breakpoint or Stop can also be used. In this case, the Breakpoint operation can be used for extended periods including saving the location and returning to finish a job later even after restarting the machine.

To create a Breakpoint:

- 1- Press the **Stop/Cancel** button during an operation.
 - a. **Pressing a 2nd time will cancel the Save Break function and the position will be lost.**
 - b. When the **Save Break** prompt appears, press **OK**.
 - c. Press **Stop/Cancel** again to discard.
- 2- The display will show the available locations (1-8).
 - a. Previously stored Breakpoints can be overwritten.
 - b. Use the **Y+/-** buttons to scroll up/down through the list.
 - c. Use the **OK** button to select the desired location.

Resuming from a Breakpoint:

Before resuming from a Breakpoint, a **HOME** operation needs to have been performed if the machine was just restarted.

- 1- When ready to resume working from the stored Breakpoint, press **Run + 1** together.
 - a. Controller will display the same **Save Break** locations seen before.
 - b. Use the **Y+/-** buttons to highlight the desired file and press **OK** to select.
 - c. The current g-code position for that break will be displayed. (**The g-code lines can be scrolled through at this point and the break resumed anywhere in the list**).
 - d. If that g-code position is acceptable, press **OK**.
 - e. The display will have moved on to the **Set Work Parameters** screen that normally appears before all file operations. Once these are approved the file will begin at the saved location.
- 2- A second way to resume working from a stored **Breakpoint** would be to press the **Break Work** button.
 - a. File must already be loaded (either from UDisk or Internal memory).
 - b. Press **Break Work** button
 - c. Prompt will give the following instructions.
 - i. Press **OK** to resume from existing break
 - ii. Press any other key to display the break line number only.
 - d. Approve speeds to begin machining if applicable

Power Failures:

During an accidental power failure, a soft version of a **Breakpoint** is set where the current parameters and coordinates are automatically saved by the system. This information will become available to resume at the next immediate start of the machine.

The information is not saved permanently, thus if it is not resumed at the next start of the machine, the information will be lost.

When power is returned to the machine, perform a **HOME** operation. Afterwards the **Want to Restore** prompt will be displayed.

Press **OK** to restart the unfinished file operation.



If the operation is Canceled, ability to resume from the saved location will be permanently lost.

Spoil Board Surfacing

Before beginning to use the machine, there are just a couple of key items that are important to cover.

First, **reading the manual**. Typically, this is not stressed enough, with many questions being asked that are often covered in the text.

Second, is the surfacing of the spoil boards which are included with the machine. Surfacing of these MDF strips ensures that the work plane is perfectly parallel to the path of the spindle while being perpendicular to the router bit itself.

Rest easy knowing that this simple surfacing operation is largely taken care of by the Axiom team. A surfacing program has been pre-loaded into the handheld controller's internal memory.

To setup and run this stored job, please refer to the previous sections covering setup of ORIGIN locations and file operations.

Then use the following:

1. Turn ON and HOME the CNC machine.
2. Set the X/Y Origin while in the HOME position.
3. Insert a 1.25" Mortising or Surfacing tool into the spindle.
***Above Bit is included in the Optional Axiom 3-pc Start Bit Set* Part number: ABS301**
4. Jog the X/Y Axes just a couple inches toward the center of the table...and use the Touch-Off Device to set the Z Axis Origin at the top of the spoil boards.
5. Set the RPM 18,000 RPM
6. Use the RichAuto B58 Controller to select the surfacing program from the internal (SD) memory.

Each Elite machine is loaded with the correct surfacing program for its table size.... with each file running both a Pocket and a Profile toolpath.

E8SFC.mmg (24" x 48")

E16SFC.mmg (48" x 48")

To begin (From the coordinate screen):

- 1- Press the **File** button located in the upper left portion of the keypad to activate the Select Work File menu.
 - a. Scroll down the list to highlight the Internal file location, press **OK** to select.
- 2- The files in that directory will then be displayed.
 - a. Highlight the desired surfacing toolpath, press **OK** to select
- 3- The controller will return to the main coordinate screen. Where the selected file will be listed at the bottom left corner of the screen and the toolpath displayed in the controller workspace.
- 4- When ready, press the **RUN/Pause/Delete** button to show the **Set Work Parameters** screen.
 - a. Press **OK** to begin the tool-path operation.

After a short count-down (4sec) during which the spindle will come up to speed, the file will begin.

***The following is the Job Setup Sheet from which all the information for the surfacing job can be seen.**



Job Setup Sheet

Job Layout



Material Border



Material Setup



Material Block:

(X):610mm (Y):1210mm
(Z):25mm

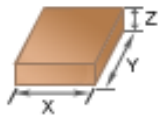

Home / Start Position:

X:0mm Y:0mm
Z:20.32mm



Datum Position:

Z-Zero:Top of Material

XY: Bottom Left Corner

Clearance Z1: 5.08mm



Toolpaths Summary



Toolpaths : 2

Tool Name:

Time Estimate : 00:16:39

Pocket 1

[1] 1.25" Mortising Bit

00:15:42

Profile 1

[1] 1.25" Mortising Bit

00:00:57

Job Setup Sheet

ELITE MASTER



Job Layout



Material Border

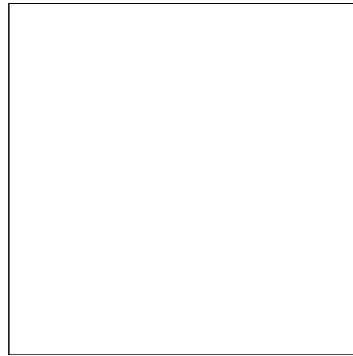

Material Setup



Material Block:

(X):1210mm (Y):1210mm
(Z):20mm

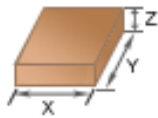

Home / Start Position:

X:0mm Y:0mm
Z:20.32mm



Datum Position:

Z-Zero:Top of Material

XY: Bottom Left Corner

Clearance Z1: 5.08mm

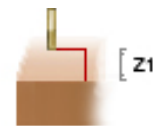

Toolpaths Summary



Toolpaths : 2

Tool Name:

Time Estimate : 01:03:35

E16PKT

[1] 1.25" Mortising Bit

01:01:02

E16PFL

[1] 1.25" Mortising Bit

00:02:33

RichAuto B58 Functions

Basic Keypad Operations:

- **FILE:** Opens the Select Work File menu
- **REPEAT MACHINING:** Repeats the last job completed
- **ADVANCED:** Enters the Advanced Functions menu
- **TOOL SWITCH:** *not supported
- **BREAK WORK:** Finds Breaks associated with current loaded file.
- **X+:** X-Axis positive movement (Right), #6 input
- **X-:** X-Axis negative movement (Left), #4 input
- **Y+:** Y-Axis positive movement (Backward), #2 input, Feed-rate % increase
- **Y-:** Y-Axis negative movement (Forward), #8 input, Feed-rate % decrease
- **C+:** C-Axis positive movement (Clockwise), #1 input
- **C-:** C-Axis negative movement (Counter-clockwise), #7 input
- **Z+:** Z-Axis positive movement (Up), #3 input, RPM % increase
- **Z-:** Z-Axis negative movement (Down), #9 input, RPM % decrease
- **FAST/SLOW:** Switches manual movement speed (F SP or L SP), #6 input
- **X/Y-0:** Manually sets the X & Y Axis to 0.00 (Programs Origin)
- **Z/C-0:** Manually sets the Z-Axis to 0.00 (Programs Origin)
- **MODE:** Manual movement selection (Continuous, Step, Distance)
- **ZRN (HOME):** Opens the HOME menu, #0 input
- **SPINDLE:** Spindle start/stop, Decimal input
- **TOOLSET:** Initiates Toolset function, Negative symbol input
- **MENU:** Open the User Interface Menu
- **REF OK (ORIGIN):** Return to the programmed ORIGIN location, confirm selection
- **RUN/PAUSE/DELETE:** Opens the Set Work Parameters menu, Begins toolpath operation
- **STOP CANCEL:** Enters the Display Function list, Cancel toolpath operations, Cancel commands

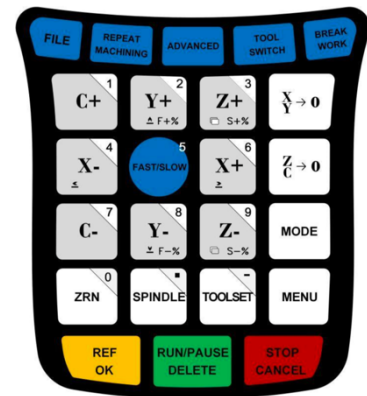

Common Combination Keypad Commands:

Key combination	Function
OK + MENU	Update Controller Software
MENU + 0	Machine Coordinate State (identified by prefix A)
MENU + (1-9)	Workpiece Coordinate States (store up to 9 different systems)

Advanced Processing

Functions found under the Advanced Processing category serve to perform a specialized task. The Advanced Processing menu can be accessed using the **Advanced Function** key.

Array:

Allows multiple copies of a file to be processed along a set number of rows and columns.

Before running an **Array**, the parameters need to be set. Such parameters will include the row/column counts and the spacing between the rows/columns.

To set the **Array** parameters:

- 1- From the coordinate screen, press **Menu**
- 2- Select **Auto Pro Setup** and scroll down to find the **Work Array** option.
- 3- The Work Array menu will be display and has several options (press **Delete** to change these settings).
 - a. Row & Column Counts-
 - b. Row & Column Spacing-
 - c. Interval-
- 4- After the parameters are setup, return to the main coordinate screen.
 - a. First, press **FILE** and select the desired toolpath.
 - b. Then access the **Advanced Process** menu by pressing **ADVANCED**.
 - c. Scroll down and select **Array Work**
 - d. The file parameters and array settings will be displayed, and operation will begin once approved.

Resume Work:

Operates much the same as using **Run/Pause + (1-8)**, to display the **Save Break** locations. (For more information see **Setting a Breakpoint**).

Mirror Work:

Allows a job to be mirrored on either the X or Y axis. (**Its recommended to use an Origin point in the center of the material**).

Tool Changing:

While the controller does not allow automatic tool changing as an option, there are a couple helpful selections available.

This option, when selected will bring the router head to the **HOME** position for tool changing and displays a prompt to press the **OK** button when finished.

Selecting **OK** will then return the Spindle head to the previous location.



This will not prompt for a Z-axis Tool Touch-Off. To avoid damage to the machine or job material, the Z-0 point must be set before continuing.

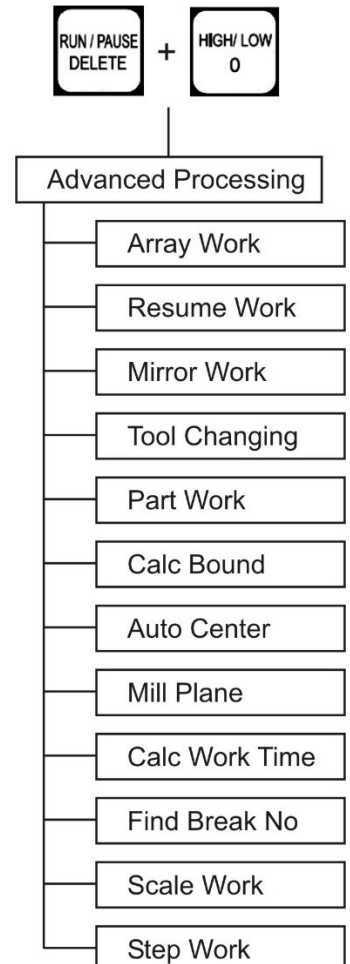

Stop State (Back Position):

In addition to the above option (**Advanced Processing Tool Changing**), there is another option which can be more effective specifically when using fixtures.

The **Stop State** shares some similarities with the **Origin** point since it will allow a defined location that can be programmed anywhere within the machine limitations.

This point must be activated in the controller software before being programmed. Once complete, the machine will go to the programmed location at the end of each process. (**Location can be changed as needed**).

To program a Stop State:

- 1- From the coordinate screen, press **Menu**.
- 2- Select **Auto Pro Setup**, then scroll down to find the **Stop State**.
- 3- The Work Stop State menu will be displayed which has several options.
 - a. **FinAct** (Finish Action)- press **Delete** to change the settings.
 - i. Pickup Z- Will leave the X & Y axis wherever they are at the end of the file operation, raising the Z-axis to the set safe height. (**Default**)
 - ii. Back to Work Origin- Will move the X & Y axes back to the **Origin**, while raising Z-axis to the safe height.
 - iii. Back Home- Will move all axes back to the **HOME** position.
 - iv. Back Position- Will move all axes to a programmed location after the file operation is complete.
 - b. Programming the **Back Position** can be done similarly to the **Origin** point. Move all axes to the desired location and height.
 - i. Press **Menu + Z-0** to set the location.
Highly recommended that the Z-axis is raised to the highest elevation to help prevent damage as the machine travels.
 - c. A specific set of coordinates can also be programmed by entering the desired location for each axis manually.

Part Work:

Using this processing option allows a specific line in the gcode from a file operation to be selected as the start and stop locations.

To setup a **Part Work** operation:

- 1- First, select the toolpath file. Then enter the **Advanced Process** menu and select **Part Work**
 - a. The gcode will be displayed.
 - i. Use the **Y+/-** buttons to scroll through the list and highlight the desired start line.
 - ii. Press **OK** to select
 - iii. Use the **Y+/-** buttons to scroll through the list and highlight the desired stop line.
 - iv. Press **OK** to select
- 2- The normal file parameters will be displayed, and operation will begin once approved.

Calculate Boundaries:

This application will calculate the boundaries of the file. Allowing a user to verify that an operation will fit within the machine limitations.

Will show the operation boundaries for each axis in metric units.

Auto Center:

Allows a pair of individual locations to be selected along the X or Y axis, from which the exact center point can be located.

To use the **Auto Center** function:

- 1- Select **Auto Center**. Then choose to find the center along either the X-axis or the Y-axis.
- 2- The display will return to the coordinate screen.
 - a. A **First of X/Y** prompt will be displayed at the bottom of the screen.
 - i. Move the X-axis to the 1st location.
 - ii. Press **OK**.
 - b. A **Second of X/Y** prompt will be displayed at the bottom of the screen.
 - i. Move the X-axis to the 2nd location.
 - ii. Press **OK**.
 - c. The X-axis will automatically adjust to the exact center of the two locations.

Mill Plane: (Surfacing Operation): ***Not recommended for machine surfacing**

Performs a near automatic surfacing program where the user enters the X & Y limits. This does not require a toolpath or the entry of gcode.

There are two types of milling options; **Scan & Encircle**.

Regardless of the type chosen, this program does not use an origin. It accepts the current position of the bit to be the starting point (0,0) with all movements based from that location. A **“soft limits error”** may occur if the limits entered cannot be supported from current location.

It is suggested that a test run be performed with the Z axis elevated above the material

To use the **Mill Plane** function:

- 1- From the **Advanced Function** menu, select **Mill Plane**. Then choose either **Scan** or **Encircle**.
 - a. **Scan** performs a surfacing program that follows a parallel path to either the X or the Y axes.
 - i. Choose either the X-axis or the Y-axis.
 - ii. Enter the X and Y axis dimensions.
 - b. **Encircle** performs a surfacing program that moves in a circular pattern around the X and Y axes, slowly working its way inward.
 - i. Choose either **AC** or **C** for movement.
 1. **AC** = counterclockwise.
 2. **C** = clockwise.
 - ii. Enter the X and Y axis dimensions.
- 2- Operation should begin immediately. Be sure that the Z axis height and RPM are properly set before using this operation.

Calculate Work Time:

This will operate much the same as Time Estimation tooling found within the chosen CAD/CAM Design Software. However, this function will allow you to calculate the operating time of a specific file based upon the file parameters in the toolpath and the machine controller settings. (**Will not factor in Speed Scale adjustments**).

Find Break No:

Like both **Resume Work** (which is also found in the Advanced Process menu) and using **Run/Pause + (1-8)**, to display the **Save Break** locations.

While similar to the **Run/Pause + (1-8)** option, this function serves two purposes. It will both find the line number of a breakpoint for a specific file or gives the option to resume working from that point.

(Unlike the Save Break menu, this will not allow for the selection a different line to resume work from).

To use the Find Break No. option:

- 1- First, select the toolpath file.
- 2- Then through the **Advanced Function** menu, select **Find Break No.**
 - a. A prompt will give the following instructions.
 - i. Press **OK** to resume from existing break
 - ii. Press any other key to display the break line number only.

Scale Work:

This feature will allow for the increase or decrease in scale existing toolpaths. Origin and all other settings will remain the same.

Be sure that there is enough room within the machine limits to support the increase in scale.

To use the **Scale Work** option:

- 1- Select the desired toolpath file.
 - a. Set scale for the X, Y & Z Axes.
 - b. Approve speeds to begin operation.

Step Work:

This function will allow the toolpath to be operated one step (one line of gcode) at a time.

To enter Step Work mode:

- 1- First, select the toolpath file.
- 2- Then through the **Advanced Function** menu, select **Step Mode.**
 - a. Prompt will give the following instructions.
 - i. Press **RUN** to continue working (normal operation).
 - ii. Press **OK** to perform steps.
 1. Each press of **OK** will perform one step.

Data Restoration and Updates

Factory set parameters and settings within the controller may be modified. It is generally recommended that any changes be done with caution unless being advised by Axiom Precision Technical Support.

These changes are easily done and may not always be intentional.

However, restoration of the factory settings is easily accomplished. Many machines have been equipped with restore files within the internal memory of the controller.

Restore files for each machine are available. If needed, the Axiom Precision Technical Support can email these files for emergency repair.

Restore/Backup Data:

Backup files can be created at the machine. It would be advisable to create these and store them via internal memory for use later should the parameters need restored.

To do this:

- 1- Press **MENU**.
 - a. Highlight **Menu Function User Interface** and press **OK**
 - b. Then scroll down and select **System Setup**.
 - c. Scroll down and select **Backup Data**.
 - i. Choose where to save the file (Flash Disk or Internal Memory)
 - d. The Data.bak file is now created with all the current settings for use later.

If the controller needs to be restored and the necessary file is not available, contact the Axiom Technical Service department at support@axiomtoolgroup.com.

- 2- To use the Axiom supplied **Restore** files:
 - a. First save the file (Data.bak) to a USB flash drive.
 - i. Insert the flash drive into the controller.
 - ii. Press **MENU**
 - iii. Highlight **Menu Function User Interface** and press **OK**
 - iv. Then scroll down and select **System Setup**.
 - v. Scroll down and select **Restore Data**.
 - vi. Choose the location where the file can be found.

A prompt will be displayed indicating that the parameters have been restored to the factory settings.

System Updates:

Occasionally as software evolves, updates may become available for the controller firmware.

When this happens, the updates may be supplied to customers from the Axiom Precision Technical Service team or downloaded from www.AxiomPrecision.com.

Much like the Backup/Restore files, the current version of the firmware Update may be used to correct certain controller software settings.

To install a **System Update**: (Emergency State Option) For use when the Menu cannot be accessed.

- 1- Save the supplied file to a USB flash drive.
 - a. With the machine powered **OFF**, insert the drive into the controller.
 - b. Enter the Emergency State mode by holding down the **OK** button as the machine is turned **ON**.
 - i. Release the **OK** button, once the loading screen appears.
 - c. Select **Update System**.
 - d. Select the location of the file (Udisk or Internal memory).
 - e. Select the file.

The update will begin automatically. Once complete the controller will display a prompt indicating that the update has been successful, the controller will need to be restarted to complete.

After restarting the machine, normal operation may be resumed.

(Normal Menu Option).

- 1- Save the supplied file to a USB flash drive.
 - a. With the machine powered **ON**, insert the drive into the controller.
 - b. From the main coordinate screen, Press the **Menu** button.
 - c. Highlight **Menu Function User Interface** and press **OK**
 - d. Scroll down and select **System Setup**.
 - e. Select **Update System**.
 - f. Select the location of the file.
 - g. Select the file.

Again, the update will begin automatically. Once complete the controller will display a prompt indicating that the update has been successful, the controller will need to be restarted to complete.

After restarting the machine, normal operation may be resumed.

Controller MENU Layout

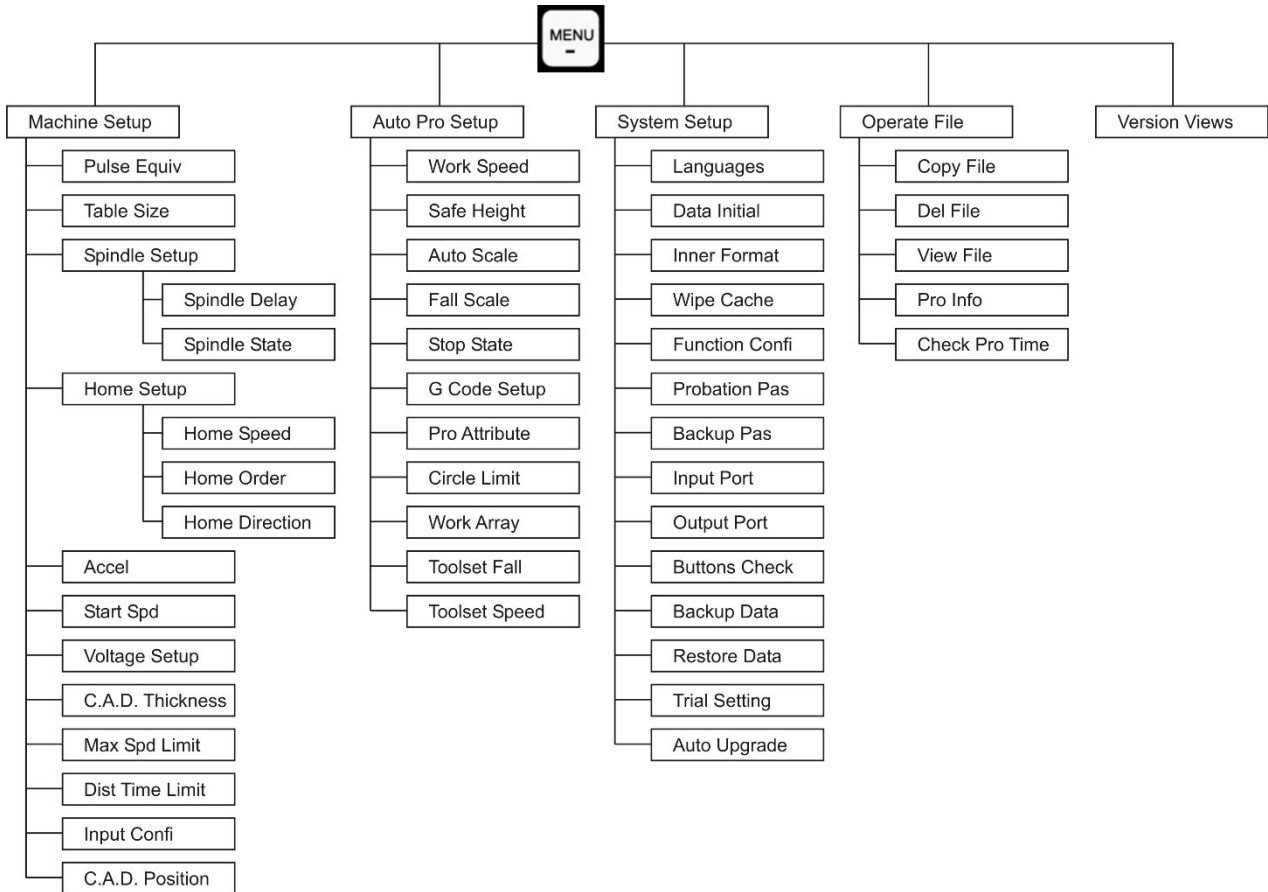

Machine Setup

These parameters are set by the manufacturer specifically for your CNC routing machine. It is usually unnecessary to change the Machine Setup defaults unless the parameters of the actual machine change.

Pulse Equivalent: Number of pulses sent by system to stepper motor for each 1mm of movement (unit: pulse/mm).

Preset Defaults: X Equivalent 1000.000
 Y Equivalent 1000.000
 Z Equivalent 2000.000
 A Equivalent 355.556

Table Size: Preset values; prevents machine over-travel. Verify table size from Specifications Chart.

Spindle Setup:

Spindle Delay: Sets the time at which the spindle starts after reading the file (unit: microseconds).

Spindle State: Sets the number of spindles in operation and the input /output shift points. Default set.

Home Setup:

Home Speed: Sets speed separately for each axis when homing; Default is X/Y: 4500 mm/sec., Z: 1800 mm/sec. and A: 500mm/sec.

Home Order: Sets desired sequence of axes when homing; Default is Z, X & Y. Will move the Z-axis first, then move the X & Y-axes together.

Home Direction: Sets each axis for positive or negative direction, based on Home position.

Acceleration: Can be adjusted to improve line and curve motions; default is 800 mm/s².

Start Speed: Sets skip speed and completion speed.

Voltage Setup: Sets input and output terminal status.

C.A.D. Thickness: Thickness of tool touch-off puck. Z-axis movement is established by the software file but can be changed here manually; Default is 25.000mm.

Max Speed Limit: Sets maximum speed of head movement; defaults are X+/- & Y+/-: 4000; Z+/- & C+/-: 2000.

Distance Time Limit: Sets period in which machine can sit idle before reverting to continuous mode; default is 5 seconds.

Input Configuration: Used to configure the pins used by the handheld controller driver board (DSP) for inputs and outputs.

C.A.D. Position: Sets the option for placement of the Z-axis device, for use in setting the Z-0 point. Default (In PLC) in place, referring to the current placement of the bit when the toolset command is triggered.

Auto Pro Setup

Work Speed: Sets work speed (default 6000 mm/min.) and fast speed (default 3000 mm/min.).

Safe Height: How high the file can process (mm); Default set to 40.000mm

Auto Scale: Used to set Speed scale, referring to the allowed percentage of tool-path movement speed. Will always be set between 0.1 (10%) to 1.0 (100%) of max feed-rate which is set in the g-code. Always set in 0.1 (10% increments. Cannot exceed max 1.0 (100%) **(See Speed Scale Adjustment)**

Fall Scale: Sets fall scale (default 0.200mm) and fall height (default 5.000mm). Fall down scale takes effect when spindle descends to fall height.

Stop State: Establishes router head stop position after machine is done: Default FinAct (Finish Action) is set for the Pickup option. This will pick up the Z-axis to the safe height parameter when the file is completed.

G Code Setup: Sets special code read configuration in G code (e.g. M,T,F,I,J,K).

Pro Attribute: Allows for a number of controller parameters to be set for specific applications.

Circle Limit: Default is 1000.00.

Work Array: Sets up array parameter, including column count, row count, column space, row space, and interval (microseconds).

Toolset Fall: Controls the distance that the Z-Axis will travel, before the controller will begin to search for the toolset signal; Default (0.00) Setting this too high may result in damaged bits when working with thick materials.

Toolset Speed: Speed of Z-Axis travel during the toolset operation.

System Setup

Languages: Default English

Data Initial: Restores factory system parameters.

Inner Format: Permanently deletes all files found on internal memory

Wipe Cache: Cleans up file fragmentation and system errors.

Function Configuration: Sets the operation parameters for a number of controller functions.

Probation Password: 20-digit password available from controller manufacturer.

Backup Password: Prevents customer parameters from overwriting original parameters. To cancel backup password, when display shows "Input New Password", do not enter a password, and press **OK**.

Input Port: Lists input pin/ports in use.

Output Port: Lists output pin/ports in use.

Buttons Check: Test function of keypad buttons. Screen display when each button is pressed; no display if button is not functioning. Press **OK** to quit.

Backup Data: Backs up menu parameters to either internal memory or flash disk, is not affected by system reformat.

Restore Data: Restore backup data to system.

Trial Setting: Set up trial passwords.

Auto Upgrade: Updates system firmware. Supports the (.pkg) file extension.

Operate File

Copy File – Copy files from U disk to internal memory.

Delete File – Delete files from internal memory.

View File – View files from either U disk or internal memory.

Processing Info – Shows number of files successfully processed.

Check Process Time – Shows time used for processing file(s).

Version View

Displays the current controller software information; preset by manufacturer.

Maintenance

To ensure proper machine operation, it is recommended that the prismatic guides and rolled ball-screws on all axis are kept clean and regularly wiped down with a light machine oil lubricant (such as 3-IN-ONE oil).

The Axiom CNC Maintenance MK468 (Not included with machine) shown here includes everything you need to keep your machine clean and in working order.

Maintenance kit link:

<https://www.axiomprecision.com/accessories/mk468.html>



Routine Checks: (Performed Daily with machine use)

1. Wipe the ball-screws and prismatic guides clean and dust free.
2. **Apply light machine oil to ball-screws and prismatic guides using a clean cloth.**
 - a. Move the machine through travel limits to properly disperse lubricant.
3. Check cutting tool edges for chips and/or dullness.
4. Generally, inspect the machine for any damage.
5. Ensure that slots in the spoil boards are free of sawdust and debris.
6. Verify that the Spindle and Collet Nut threads are clean of debris and undamaged.
7. Check coolant levels in reservoir.
8. Verify that the dust extractor is free of blockages.
9. Check that all electrical connectors are fitted correctly, are tight and damage free.

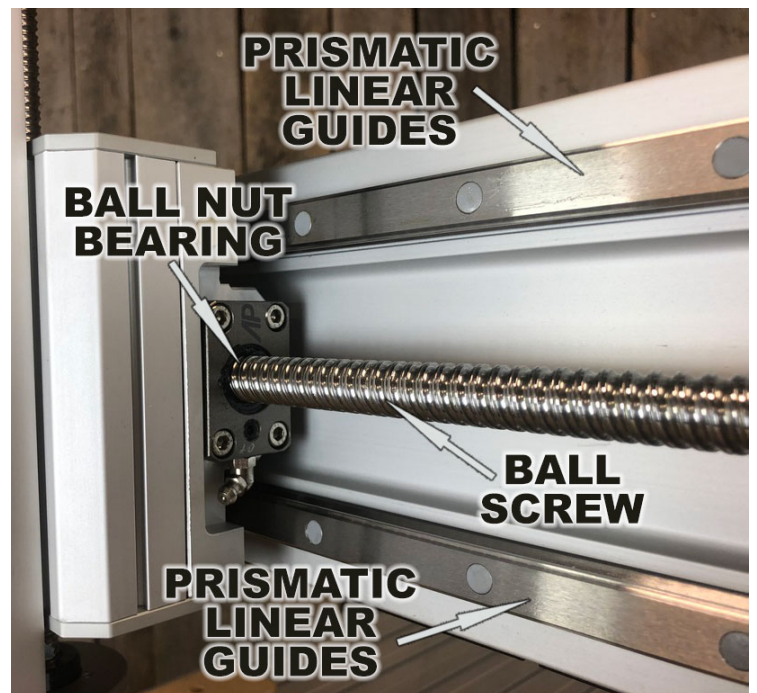

Cooling System Flush/Refill:

On AutoRoute Elite series machines, every 4-6 months the electro spindle cooling system should be flushed and refilled to guarantee that the coolant is fresh and able to perform optimally.

The cooling system consists of a clear reservoir/pump assembly.

To flush this system, it is recommended that users acquire the following:

1. A small (12 inch) section of 5mm tubing. (Included in MK468 CNC Maintenance kit)
2. Empty container used to catch old fluid.
3. Container of distilled water (Flush).
4. Fresh Propylene Glycol (RV/Marine Grade) coolant.

First, locate the cooling system which can be found on the rear side of the gantry. Uncover the cooling system by removing the 3-screws which hold the black cover in place.

Once the cover is removed, notice the cooling pump/reservoir, as seen here:

The output from the pump is going directly into the radiator. From there the fluid travels up the wire chain to the spindle then back to the pump through the return tube.

To flush the system, removing all the old coolant and preparing for the new fluids:

1. Remove the black plug from the purge valve. The black collar attached to the elbow will need to be pressed in while you pull the black plug out, as seen here:
2. Attach a short section of tubing to that same fitting and run it to an empty container.
3. Move the toggle switch to the (Flush) position.

Make sure the spindle RPM is turned to Zero (F0.00). Then from the main coordinate screen, manually cycle the spindle/pump on by pressing the ON/OFF button on the controller.

This will cause the pump to draw up the distilled water (Flush) and push out the old fluids and water through the other line.

Once the coolant has been flushed from the system. Press the ON/OFF button again to stop pump.

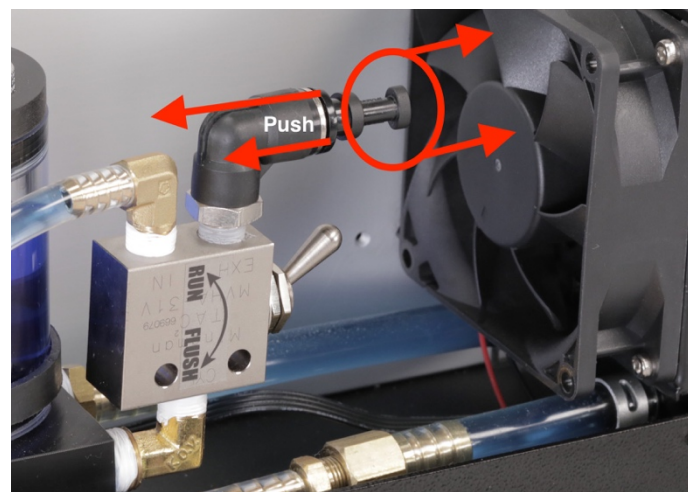
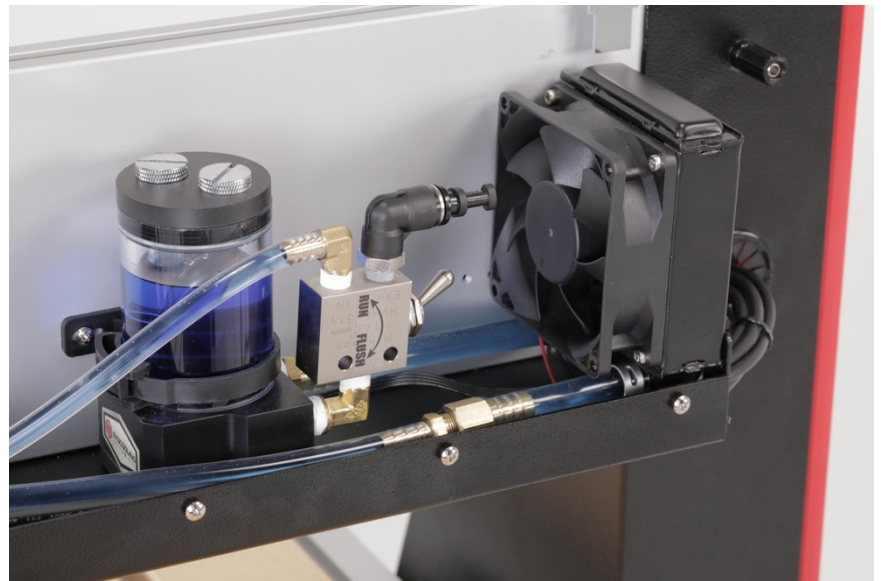
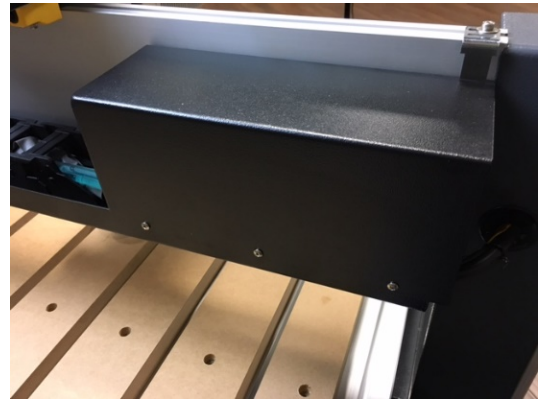

Next, replace the distilled water (Flush) with the new coolant, by repeating the above purge steps.

Once all the distilled water (Flush) has been removed from the system and replaced with the proper coolant, stop the pump by pressing the ON/OFF button on the controller and move the toggle switch back to the run position.

Remove the temporary section of tube used for flushing and reconnect the black plug.

Continue to fill the reservoir with the proper coolant filling the tank and turn the spindle on by pressing the SPINDLE button on the controller.

With the pump running top off the tank to approximately $\frac{3}{4}$ full, using the remaining coolant.

When finished, be sure to reinstall the pump cap and turn the spindle off using the SPINDLE button on the controller

Entire system holds between 14 and 20oz of fluid. It should not take much to flush and refill the system

Ball Nut Bearing Service (500-Hour):

On all Elite series machines, it is recommended that the ball-nut bearing assembly be serviced every 500 machine hours.

The rolled ball screws which are found on each axis of any Axiom CNC machine feature a re-circulating bearing assembly (ball-nut bearing) which simply rides along the threaded shaft of the rolled ball screws...transferring the rotation of the stepper motors into linear movement along an axis.

Each of these bearing assemblies includes a grease fitting which can be used for lubrication during your service.

*Most any mineral-oil based grease can be used...**Lucas Oil Xtra Duty** is most often recommended* Both the grease gun and necessary grease are included in the Axiom CNC Maintenance kit (MK468)

To Lubricate this bearing assembly:

1. Position the Axis near the middle of its travel.
2. Loosen and remove the bearing assembly mounting screws (4 cap-screws per assembly)
3. Slide the Axis away from the bearing assembly.

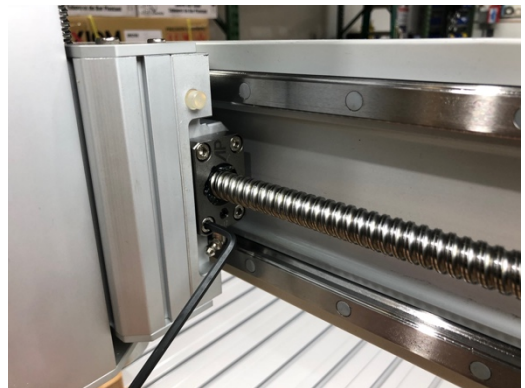

4. Attach the grease gun to the grease fitting.

5. Use gentle pressure to insert grease into the assembly...being careful to not damage the seals.



It has been found to be advantageous to use the handheld controller to move the bearing assembly along the axis in both the +/- directions while the grease is being introduced. Allowing the grease to more effectively work into the assembly

6. Reposition the bearing assembly to the Axis.



7. Reinsert the mounting screws...leaving them slightly loose.

8. Use the controller to move this Axis to the far + direction.... placing the bearing assembly closest to the fixed end of the Axis



9. Continue to service the next axis or resume normal operation.

Troubleshooting:

Mechanical & Electrical Problems:

Symptom	Possible Cause	Correction *
Motor will not start, fuses blow or circuit breakers trip.	Short circuit in line cord or plug.	Inspect cord or plug for damaged insulation and shorted wires.
	Loose or separated connection.	Inspect all connections between motor and control box. *Some connections may be hidden.
	Blown Fuse	Test and Install correct fuses.
Motor attempts start but will not turn.	Jammed spindle.	Disconnect from power, try turning spindle by hand. Check reason for jamming.
	Motor faulty.	Replace spindle.
	Spindle runs without coolant.	Replace motor. Maintain coolant level.
	Incorrect voltage.	Check incoming voltage.
Motor overheats (shuts off).	Dull cutting tools.	Use sharp tools.
	No coolant in reservoir, or blockage in coolant path.	Fill reservoir, check for obstacles in flow path.
Motor stalls, resulting in blown fuses or tripped circuit.	Motor overloaded.	Reduce load on motor.
	Short circuit in motor or loose connections.	Inspect connections on motor for loose or shorted terminals or worn insulation.
	Low voltage.	Correct low voltage conditions.
	Incorrect fuses or circuit breakers in power line.	Install correct fuses or circuit breakers.
Router cutting depth inconsistent.	Loose cutter.	Tighten cutter in spindle collet.
	Spoil boards not flat.	Check that spoil boards are flat and clean prior to fitting job.
	Excessive play in Z-axis ball screw.	Inspect and correct if needed.
Machine won't power on.	E-stop switch engaged.	Release red E-stop switch.
	No incoming power.	Check power plug connection. Check condition of power cable.
	Faulty start switch.	Inspect and replace.
	Internal breaker faulty.	Replace breaker.
Machine will not home.	Limit switches damaged, disconnected or misadjusted.	Inspect limit switches and correct problem.

Symptom	Possible Cause	Correction *
Controller display is blank or flickering.	Cable connections not tight.	Inspect and tighten connections between pendant and control box.
	Loose 24V connection to control board.	Check the 24V connection to the DSP control board in the control box.
	Interface damaged.	Replace damaged part.
	Controller damaged.	Replace controller.
Controller keeps restarting automatically.	Insufficient power supply.	Have qualified electrician check incoming power supply.
	Local power grid unstable.	Contact power company.
	Controller damaged.	Connect controller to computer via USB cable. If problem still occurs, replace controller.
Controller display reads "Out of Limit".	HOME operation has not been performed.	HOME all axes and retry.
	Design too large to fit within machine limits.	Check ORIGIN placement and design size.
	Incorrect table size.	Check table size parameters in Machine Setup.
Cannot set work origin on controller.	May be in Machine Coordinate State	Press MENU + 1 to revert to first working coordinate system.
	Buttons not functioning.	Enter MENU /System Setup/Buttons Check to verify function. If buttons not working, replace controller.
Z-axis fall is too fast during processing.	Working speed exceeds Z-axis maximum speed.	Set to safe speed in: MENU /Machine Setup/Max Speed Limit.
	Loose coupling, or transmission slipping.	Tighten connecting parts.
	Incorrect plunge speed in design software.	Check speeds and verify correct post processor is being used.
Z-axis depth not consistent each time same file is processed and after machine homes.	Spoil board or material not flat.	Re-mill (surface) spoil board/material
	Workpiece not consistent thickness	Check consistency
	Interference in Z-axis HOME process is creating a false origin.	Re-HOME Z-axis and check for proper operation.
Processed workpiece does not match file size.	Pulse equivalent incorrect.	Adjust pulse under: MENU /Machine Setup.
	Incorrect post processor	Verify that correct post processor was used.
	Wrong cutting tool used.	Use proper tool for process.

Symptom	Possible Cause	Correction *
Machine not stopping at HOME position	HOME detection plate beyond reach of proximity sensors.	Inspect and adjust.
	Proximity sensor wire is loose or damaged.	Check connections.
	Proximity sensor damaged.	Test and Replace.
	Poor connection at Interface board.	Inspect the appropriate connection.
	50-pin data cable is broken.	Replace cable.
Machine moves reverse direction when homing.	Incorrect HOME direction settings in Machine Setup.	Check settings.
	50-pin data cable is broken.	Replace data line.
Router head does not stop after contacting tool touch-off puck.	Poor connection of between the touch-off device and gantry connections.	Inspect connections inside touch-off device and gantry.
	Poor connection of spindle with "GND" terminal on interface board.	Restore proper connection.
Machine will not move after controller receives commands.	One axis not moving – may be poor connection.	Connect a different axis connection to this terminal to test. If it works, motor driver is okay. Check connections along corresponding drive and motor.
	All axes not moving.	First, check 50-pin cable connection to interface board. Then check power supply of motor drivers. Last check mechanical elements of axis system.
Machine moves to new position satisfactorily but does not return correctly to original position.	Mechanical elements, such as ball screws, are loose or misadjusted.	Inspect and correct as needed.
	The Stepper motors have slipped, and lost position.	Check speeds and proper lubrication on all ball screws and prismatic guides.
Abnormal operation when processing.	Program/drawing file is faulty.	Review program and reload to system. Make sure the file is completely saved before removing USB from PC.
After controller powers on, one or more axes move only one direction.	Improper connection between DSP board and motor drive.	Inspect connections.

AR8 Elite Part List:

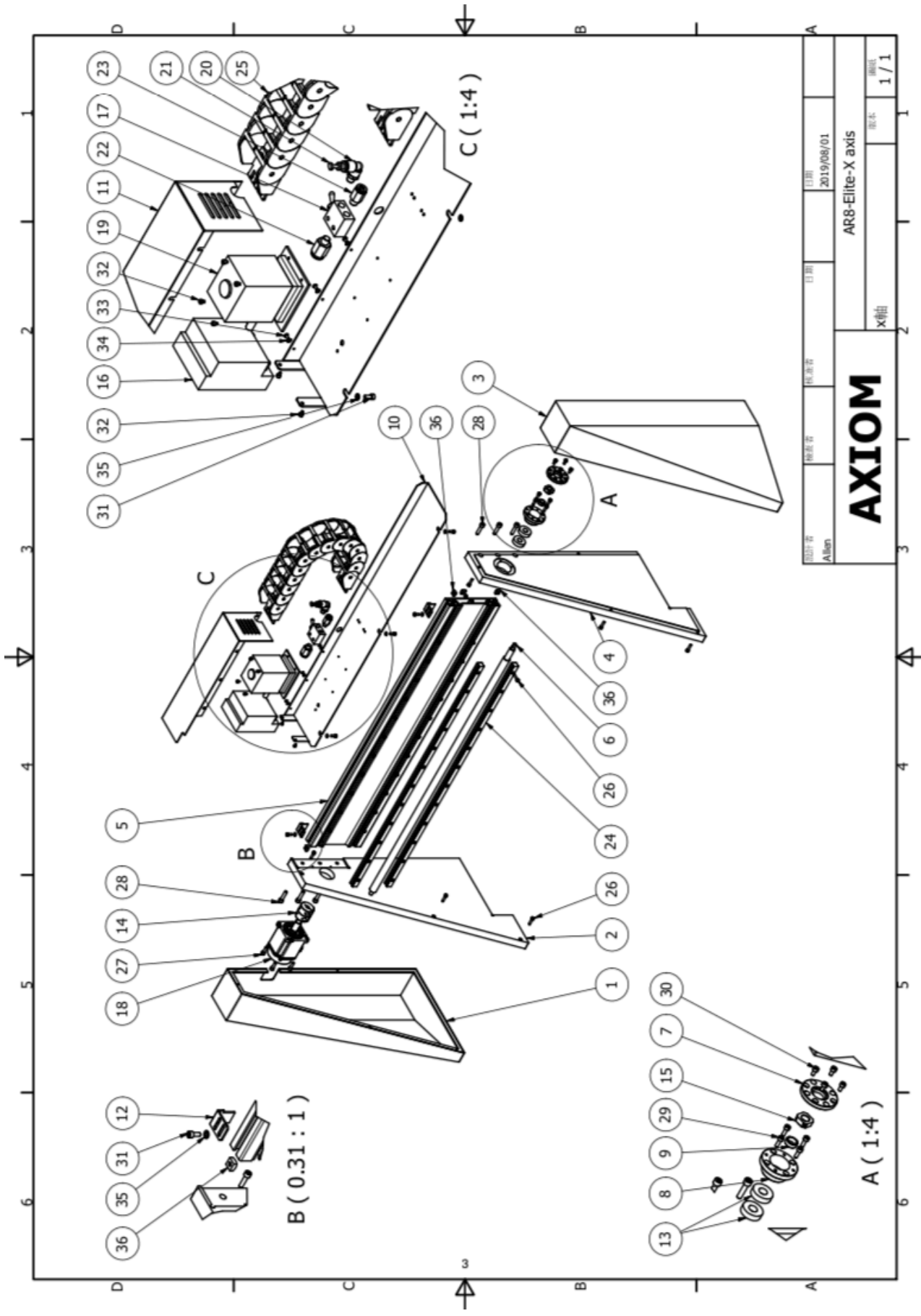

设计者 Axiom	审核者	日期 2019/08/01	图号 AR8-Elite-X axis
AXIOM			版本 1/1
			轴名 X轴

NO.	PART NO.	PART NAME	DESCRIPTION	QTY.
1	AX0102541	LEFT SIDE COVER		1
2	AX0102530	LEFT GANTRY		1
3	AX0102551	RIGHT SIDE COVER		1
4	AX0102521	RIGHT GANTRY		1
5	AX0100042	X AXIS ALUMINIUM EXTRUSION		1
6	AX0100070	X AXIS BALL SCREW		1
7	AX0100131	BEARING COVER		1
8	AX0100151	BEARING SEAT		1
9	AX0100191	SPACER		1
10	AX0100186	X AXIS DRAG CHAIN SEAT LOWER		1
11	AX0100472	COOLING SYSTEM COVER		1
12	AX0100260	SENSOR RESPONSE PLATE		2
13	TPI-7001AHTP5	BEARING		2
14	SRC-32C(8,14)	COUPLING		1
15	RN-12X1.0P	LOCK NUT		1
16	AX01C00073	RADIATOR(80D)		1
17	MVHA-31V	HAND VALVE		1
18	SME-L020	SERVO MOTOR(200W)		1
19	AX01C00027	PUMP (SC-300T)		1
20	MJELLS8-1-B	L SHAPE MALE CONNECTOR		1
21	BSLG8	BLIND PLUG		1
22	MJCNLS10-1	M10 CONNECTOR		1
23	MJCNLS8-1	M8 CONNECTOR		1
24	STAF-BGXS15BN-1-700-NZ0	X AXIS LINEAR GUIDE		2
25	A0450.21 KR52-658MM	X AXIS DRAG CHAIN		1
26	HS-SCW-M4X16	HEX SOC HD SCR	M4x16	32
27	HS-SCW-M5X16	HEX SOC HD SCR	M5x16	4
28	HS-SCW-M6X20	HEX SOC HD SCR	M6x20	6
29	HS-SCW-M4X12	HEX SOC HD SCR	M4x12	4
30	HS-SCW-M4X8	HEX SOC HD SCR	M4x8	6
31	HS-SCW-M4X10	HEX SOC HD SCR	M4x10	5
32	HS-SCW-M3X6	HEX SOC HD SCR	M3x6	6
33	HSB-SCW-M3x6	HEX SOC HD CAP SCR	M3x6	3
34	W-M3	FLAT WASHER	M3	3
35	W-M4	FLAT WASHER	M4	5
36	3030M4	SQUARE NUT	M4	29

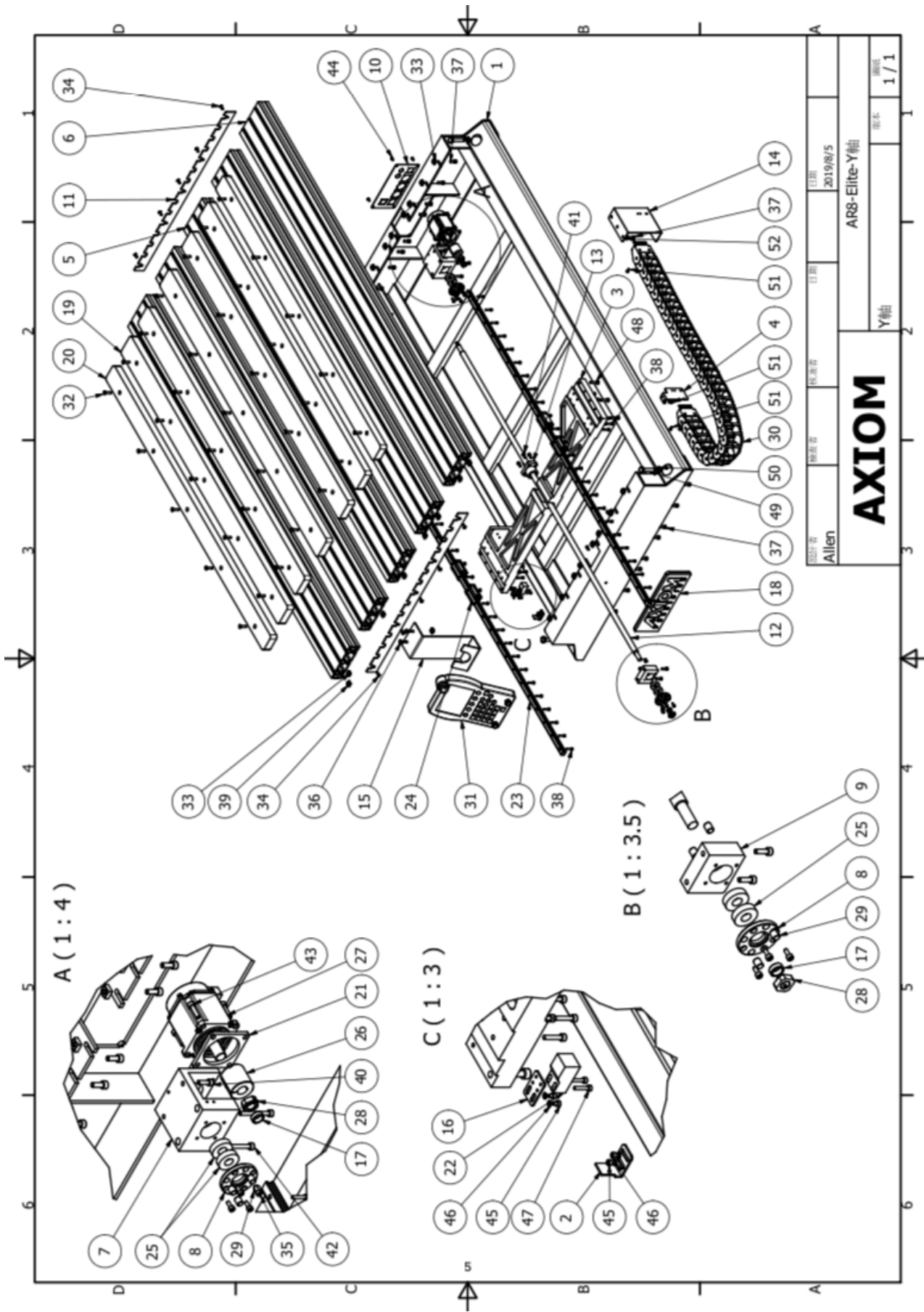

品牌	Allen	系列	AR8-Elite-Y轴
图号	2019/8/5	比例	1/1
<h1 style="text-align: center;">AXIOM</h1>		轴	Y轴
		版本	1/1

NO.	PART NO.	PART NAME	DESCRIPTION	QTY
1	AX0102501	BASE REAR PLATE		1
2	AX0100260	SENSOR RESPONSE PLATE		2
3	AX0100024	Y AXIS SLIDE SEAT		1
4	AX0100241	Y AXIS DRAG CHAIN FIXED PLATE A		1
5	AX0100401	Y AXIS ALUMINIUM EXTRUSION TABLE (MIDDLE)		1
6	AX0100010	Y AXIS ALUMINIUM EXTRUSION TABLE		4
7	AX0102340	Y&Z AXIS MOTOR SEAT		1
8	AX0100131	BEARING COVER		2
9	AX0100461	Y AXIS BALL SCREW SEAT		1
10	AX0102430	BASE REAR PLATE		1
11	AX0100230	TABLE SIDE PLATE		2
12	AX0100391	Y AXIS BALL SCREW		1
13	AX0100391	Y AXIS BALL SCREW(NUT)		1
14	AX0100331	Y AXIS DRAG CHAIN FIXED PLATE B		1
15	AX0102560	CONTROLLER HOLDER		1
16	AX0100222	SENSOR FIXED PLATE		2
17	AX0100191	SPACER		2
18	AX0400130	AXIOM NAME PLATE		1
19	AX0100582	WOOD PLATE(MIDDLE)		5
20	AX0100590	WOOD PLATE(2 SIDE)		2
21	AX0102350	MOTOR PLATE		1
22	DA-1805NO	SENSOR		2
23	STAF-BGXS15BN-2-820-NZ0-20-20	Y AXIS LINEAR GUIDE		2
24	BGXS15BN	SLIDING BLOCK		4
25	TPI-7001AHTP5	BEARING		4
26	SRC-32C(8,14)	COUPLING		1
27	SME-L020	SERVO MOTOR(200W)		1
28	RN-12X1.0P	LOCK NUT		2
29	CXHK8-10	CUSHION PAD		6
30	"A0450.21 KR52-1551MM"	Y AXIS DRAG CHAIN		1
31	AX04C0001	HANDHELD CONTROLLER		1
32	FH-SCW-M6x25	HEX SOC FLAT HD CAP SCR		35
33	4040M6	SQUARE NUT	M6	56
34	HSB-SCW-M5x12	HEX SOC HD CAP SCR	M5x12	10
35	HS-SCW-M4X10	HEX SOC HD SCR	M4x10	10
36	HS-SCW-M6X12	HEX SOC HD SCR	M6x12	2
37	HS-SCW-M6X16	HEX SOC HD SCR	M6x16	19
38	HS-SCW-M4X16	HEX SOC HD SCR	M4x16	64
39	4040M4	SQUARE NUT	M4	48
40	HS-SCW-M5X16	HEX SOC HD SCR	M5x16	4
41	HS-SCW-M5X12	HEX SOC HD SCR	M5x12	4
42	HS-SCW-M5X45	HEX SOC HD SCR	M5x45	2
43	HS-SCW-M5X20	HEX SOC HD SCR	M5x20	4
44	THP-SCW-M4x8	TRUSS HD PHILLIPS SCR	M4x8	4

45	HS-SCW-M3X6	HEX SOC HD SCR	M3x6	8
46	W-M3	FLAT WASHER	M3	8
47	HS-SCW-M3X20	HEX SOC HD SCR	M3x20	4
48	HS-SCW-M6X25	HEX SOC HD SCR	M6x25	6
49	HH-SCW-M10X45	HEX HD SCR	M10x45	4
50	S-M10	FLAT WASHER	M10	4
51	HS-SCW-M4X8	HEX SOC HD SCR	M4x8	6
52	W-M6	FLAT WASHER	M6	3

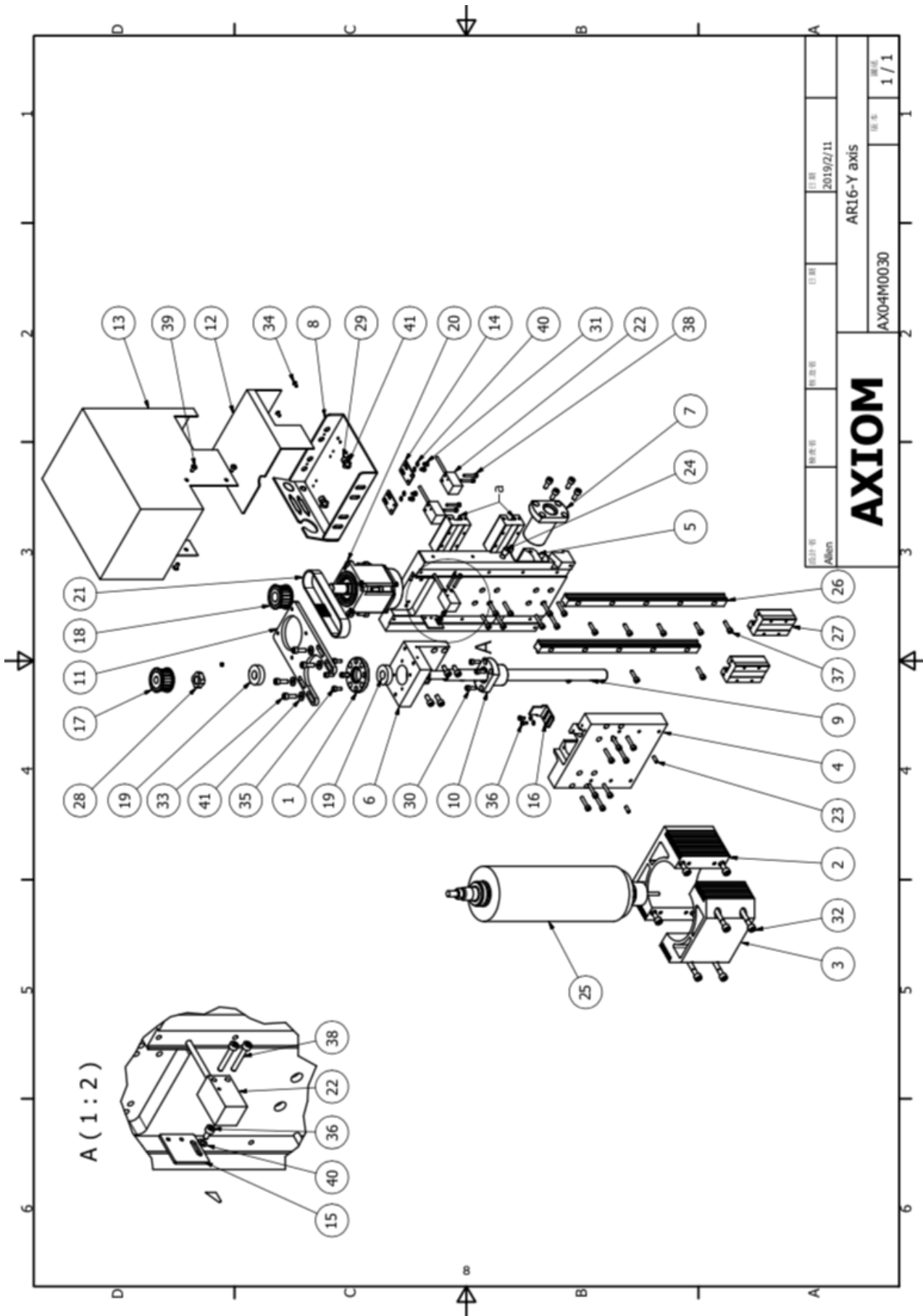

NO.	PART NO	PART NAME	DESCRIPTION	QTY
1	AX0100131	BEARING COVER		1
2	AX0100091	SPINDLE MOUNT A		1
3	AX0100100	SPINDLE MOUNT B		1
4	AX0100083	Z AXIS SLIDE SEAT		1
5	AX0400040	X AXIS SLIDE PLATE		1
6	AX0400061	Z AXIS BEARING SEAT		1
7	AX0400320(NUT)	X AXIS BALL SCREW(NUT)		1
8	AX0102094	X AXIS DRAG CHAIN SEAT UPPER		1
9	AX0400050	Z AXIS BALL SCREW		1
10	AX0400050(NUT)	Z AXIS BALL SCREW(NUT)		1
11	AX0400070	Z AXIS MOTOR MOUNTING		1
12	AX0102101	X AXIS DRAG CHAIN COVER		1
13	AX0400080	Z AXIS TOP COVER		1
14	AX0100220	SENSOR FIXED PLATE		2
15	AX0400290	SENSOR FIXED PLATE		1
16	AX0100260	SENSOR RESPONSE PLATE		1
17	AX0400551	BELT PULLEY		1
18	AX0400561	BELT PULLEY		1
19	TPI-7001AHTP5	BEARING		2
20	SME-L04030SAAU(400W)	SERVO MOTOR (400W)		1
21	GBN275EV5GT-150 .info-1-18-18	V-BELT		1
22	DA-1805NO	SENSOR		3
23	Pin4x10	PIN 4x10		2
24	Misumi_CXHK8-10	CUSHION PAD		2
25	GDZ-23-1C Φ80/2.2	SPINDLE MOTOR (2.2KW)		1
26	BGXS15BN-1-280-N-Z0	X AXIS BALL SCREW		2
27	BGXS15BN-1-280-N-Z0	SLIDE BLOCK		4
28	RN-12X1.0P	LOCK NUT		1
29	HS-SCW-M5X12	HEX SOC HD SCR	M5x12	14
30	HS-SCW-M4X12	HEX SOC HD SCR	M4x12	4
31	HS-SCW-M3X6	HEX SOC HD SCR	M3x6	4
32	HS-SCW-M6X35	HEX SOC HD SCR	M6x35	8
33	HS-SCW-M5X16	HEX SOC HD SCR	M5x16	4
34	HSB-SCW-M3x6	HEX SOC HD CAP SCR	M3x6	2
35	HS-SCW-M4X10	HEX SOC HD SCR	M4x10	4
36	HS-SCW-M3X8	HEX SOC HD SCR	M3x8	3
37	HS-SCW-M4X16	HEX SOC HD SCR	M4x16	25
38	HS-SCW-M3X18	HEX SOC HD SCR	M3x18	6
39	HS-SCW-M4X8	HEX SOC HD SCR	M4x8	4
40	W-M3	FLAT WASHER	M3	7
41	W-M5	FLAT WASHER	M5	6
42	AX01C00009	AXIOM TAG		1

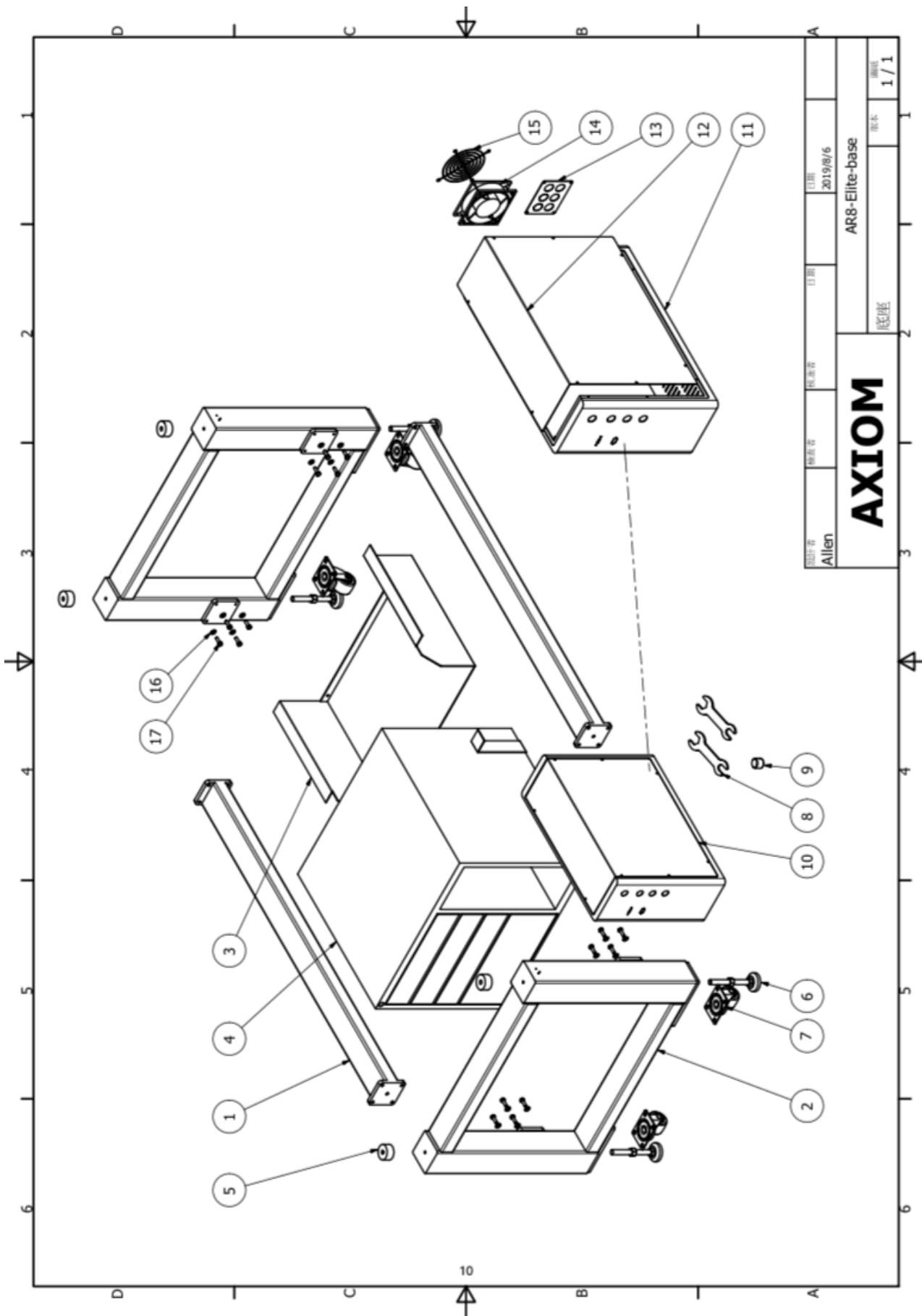

NO.	PART NO.	PART NAME	DESCRIPTION	QTY.
1	AX0100632	BEAM ASSEMBLY B-24X48		2
2	AX0100606	BEAM ASSEMBLY A		2
3	AX0100660	TOOL HOLDER PLATE		1
4	AX0100680	TOOLBOX		1
5	AX01C00044	DAMPING PLATE		4
6	TX102-1-6016-150	ANTI-DAMPING LEG (WITH NUTS)		4
7	11090300201	NYLON CASTER		4
8	AX0100671	OPEN WRENCH		2
9	AX0100530	TOOL PUCK (WITH WRENCH 2mm)		1
10	ESHE10B10	ROUTER ELECTRICAL BOX V1.0 (AR8 ELITE)		1
11	AX0102392	ELECTRICAL CONTROL BOX		1
12	AX0102442	ELECTRICAL CONTROL BOX - L COVER		1
13	AX0102420	CONNECTER PLATE		1
14	DP200A-2123XBT.GN	220V FAN		1
15	FAN COVER	FAN COVER		1
16	W-M8	FLAT WASHER	M8	16
17	HH-CSW-M8X25	HEX HD SCR	M8X25	16

AR16 Elite Part List:

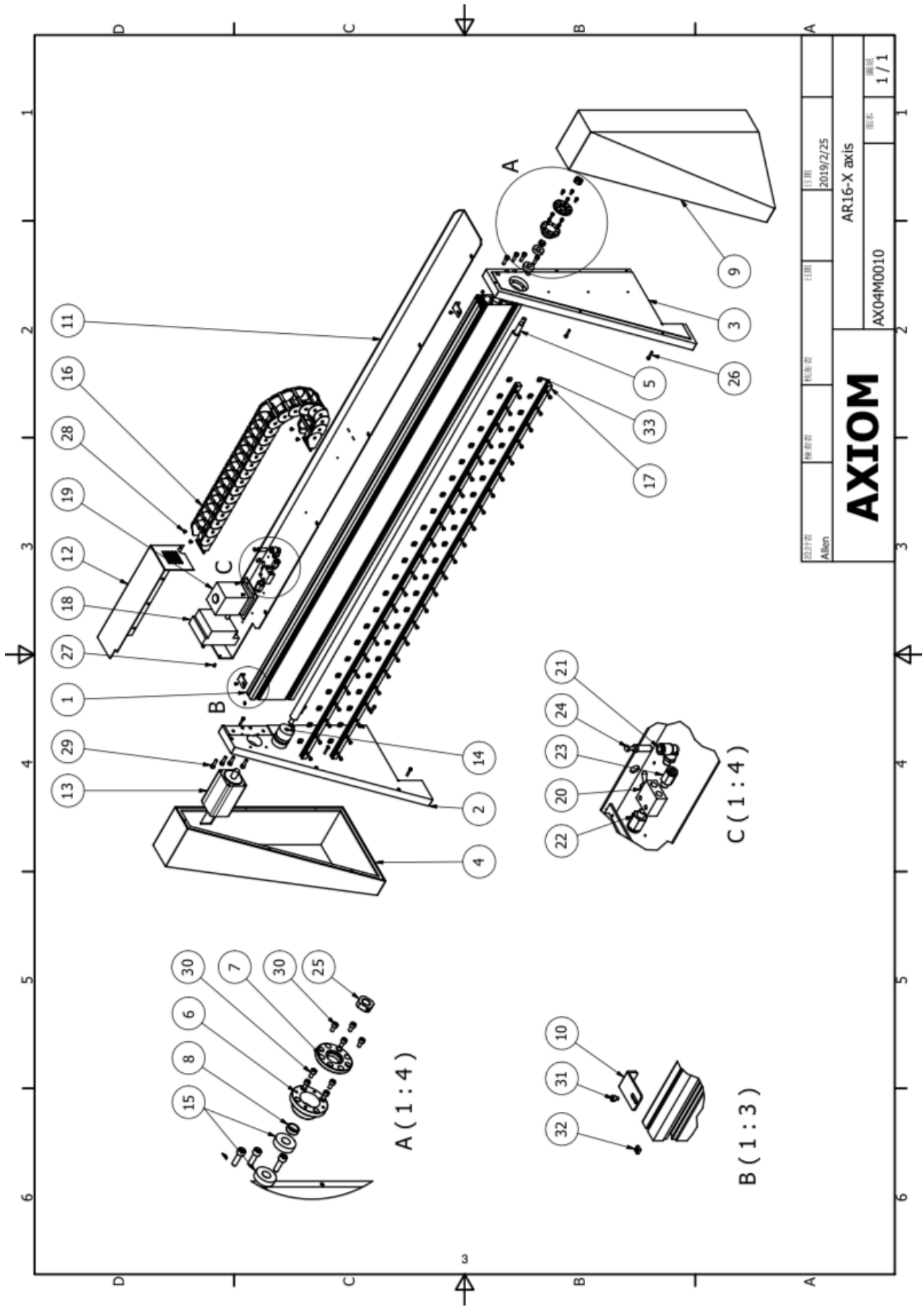

设计者 Allen	审核者	标准号	日期 2019/2/25
AXIOM			图号 1/1
AXO-M0010		AR16-X axis	

NO.	PART NO.	PART NAME	DESCRIPTION	QTY
1	AX0400650	X AXIS ALUMINIUM EXTRUSION	1442MM LONG	1
2	AX0400201	LEFT GANTRY		1
3	AX0400301	RIGHT GANTRY		1
4	AX0400210	LEFT SIDE COVER		1
5	AX0400320	X AXIS BALL SCREW		1
6	AX0100151	BEARING SEAT		1
7	AX0100131	AXIOM NAME PLATE		1
8	AX0100191	SPACER		1
9	AX0400311	RIGHT SIDE COVER		1
10	AX0400660	SENSOR RESPONSE PLATE		2
11	AX0400190	X AXIS DRAG CHAIN SEAT LOWER		1
12	AX0100472	COOLING SYSTEM COVER		1
13	SME-L04030SAAU(400W)	SERVO MOTOR (400W)		1
14	X5F-RAB32-10x14	COUPLING		1
15	TPI-7001AHTP5	BEARING		2
16	A0450.21 KR52-1130mm	X AXIS DRAG CHAIN		1
17	BGXS15BN-1-1360-N-Z0	X AXIS LINEAR GUIDE		2
18	AX01C00073	RADIATOR (80D)		1
19	AX01C00027	PUMP (SC-300T)		1
20	MVHA-31V	MVHA-31-HAND VALVE		1
21	MJELLS8-1-B	L SHAPE MALE CONNECTOR		1
22	MJCNLS10-1	M10 CONNECTOR		1
23	MJCNLS8-1	M8 CONNECTOR		1
24	BSLG8	BLIND PLUG		1
25	RN-12X1.0P	LOCK NUT		1
26	HS-SCW-M4X20	HEX SOC HD SCR	M4x20	56
27	HS-SCW-M3X6	HEX SOC HD SCR	M3x6	9
28	FH-SCW-M4x6	HEX SOC FLAT HD CAP SCR	M4x6	4
29	HS-SCW-M6X20	HEX SOC HD SCR	M6x20	8
30	HS-SCW-M4X8	HEX SOC HD SCR	M4x8	8
31	HS-SCW-M3X6	HEX SOC HD SCR	M3x6	2
32	HEX NUTS-M3	HEX NUTS	M3x6	7
33	3030M4	SQUARE NUT	M4	46

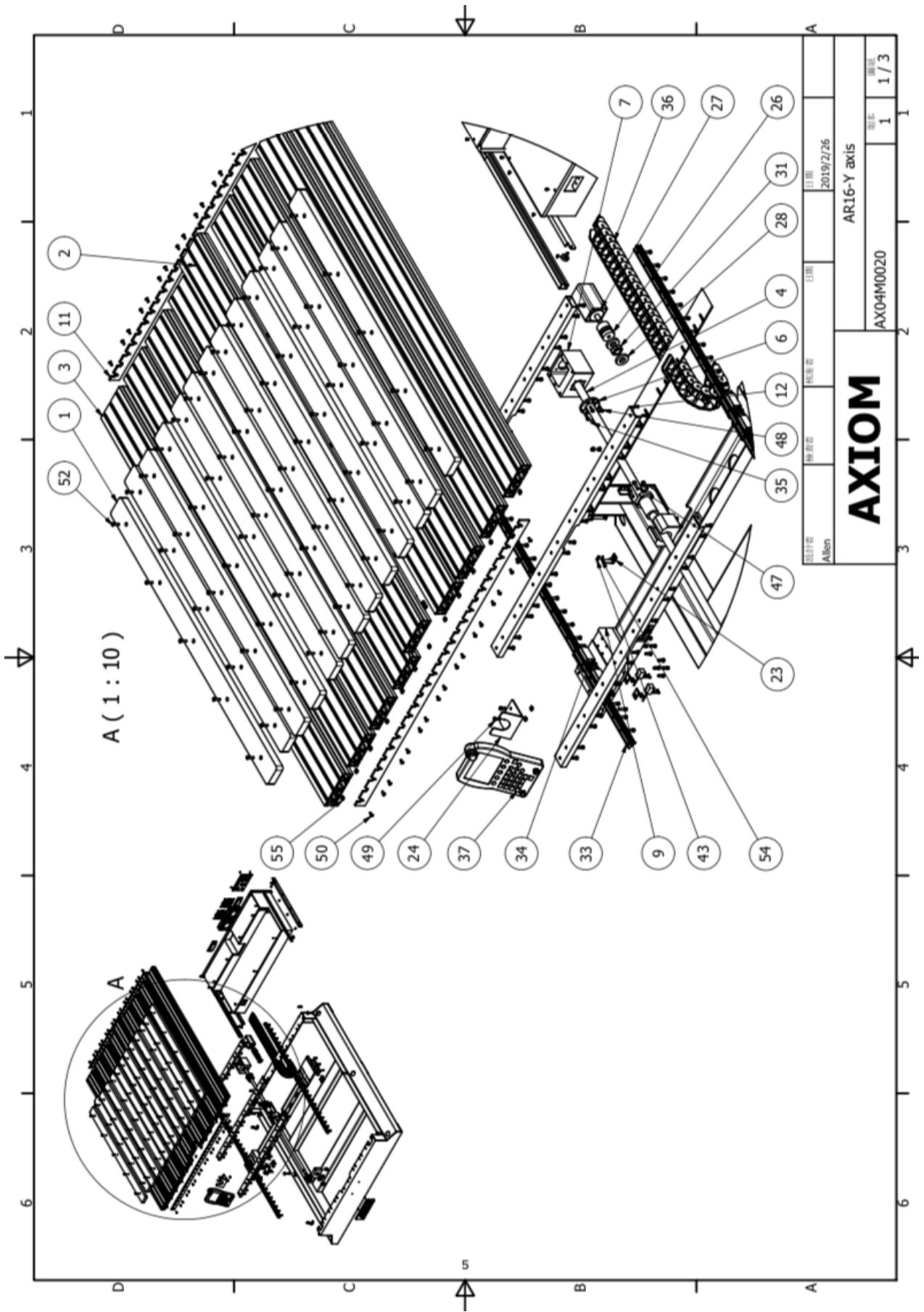

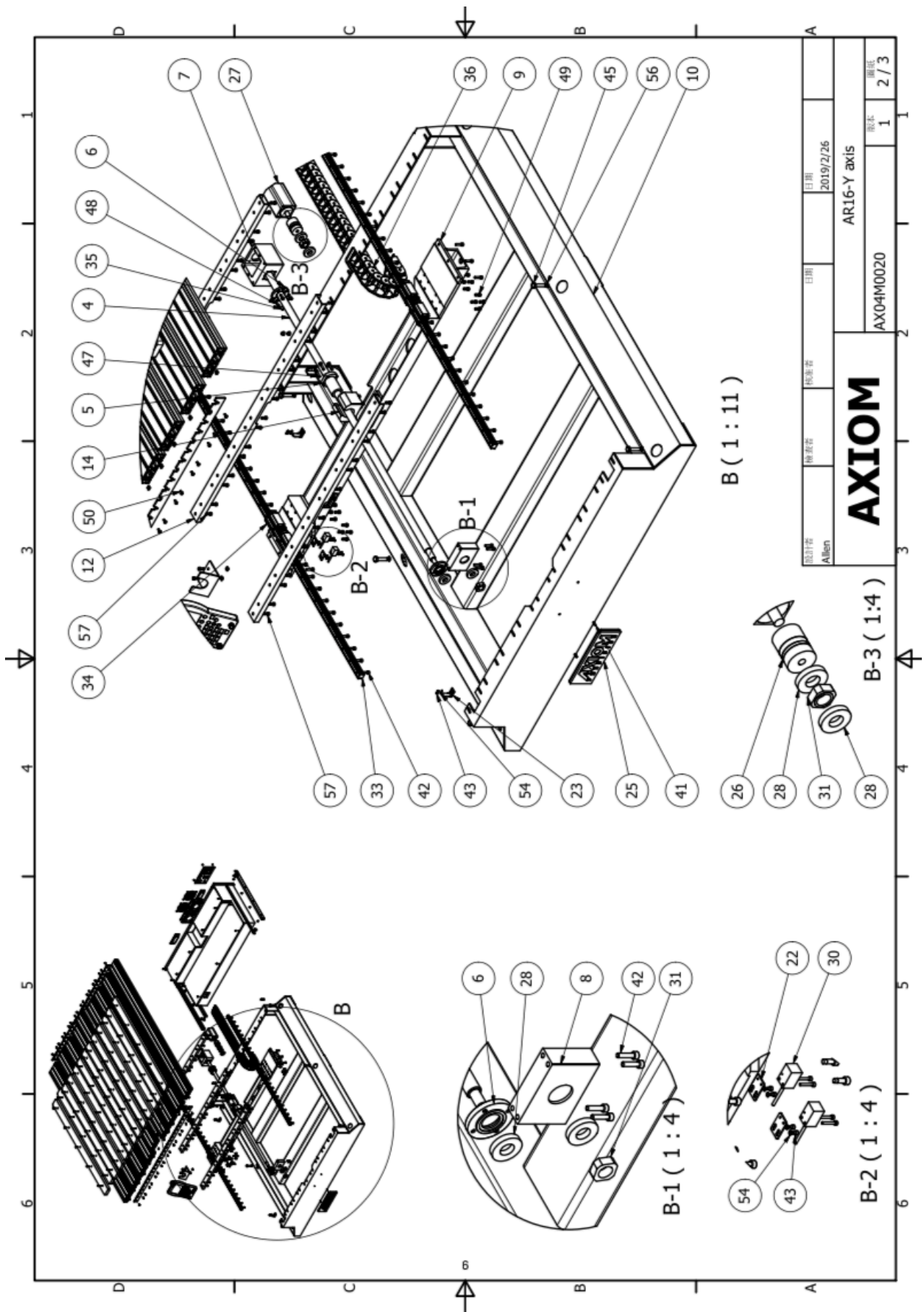

設計者 Allen	検査者	検査日	2019/2/26
AXIOM		製品名	AR16-Y axis
		部品番号	AX04M0020
		版本	1
		編成	2 / 3

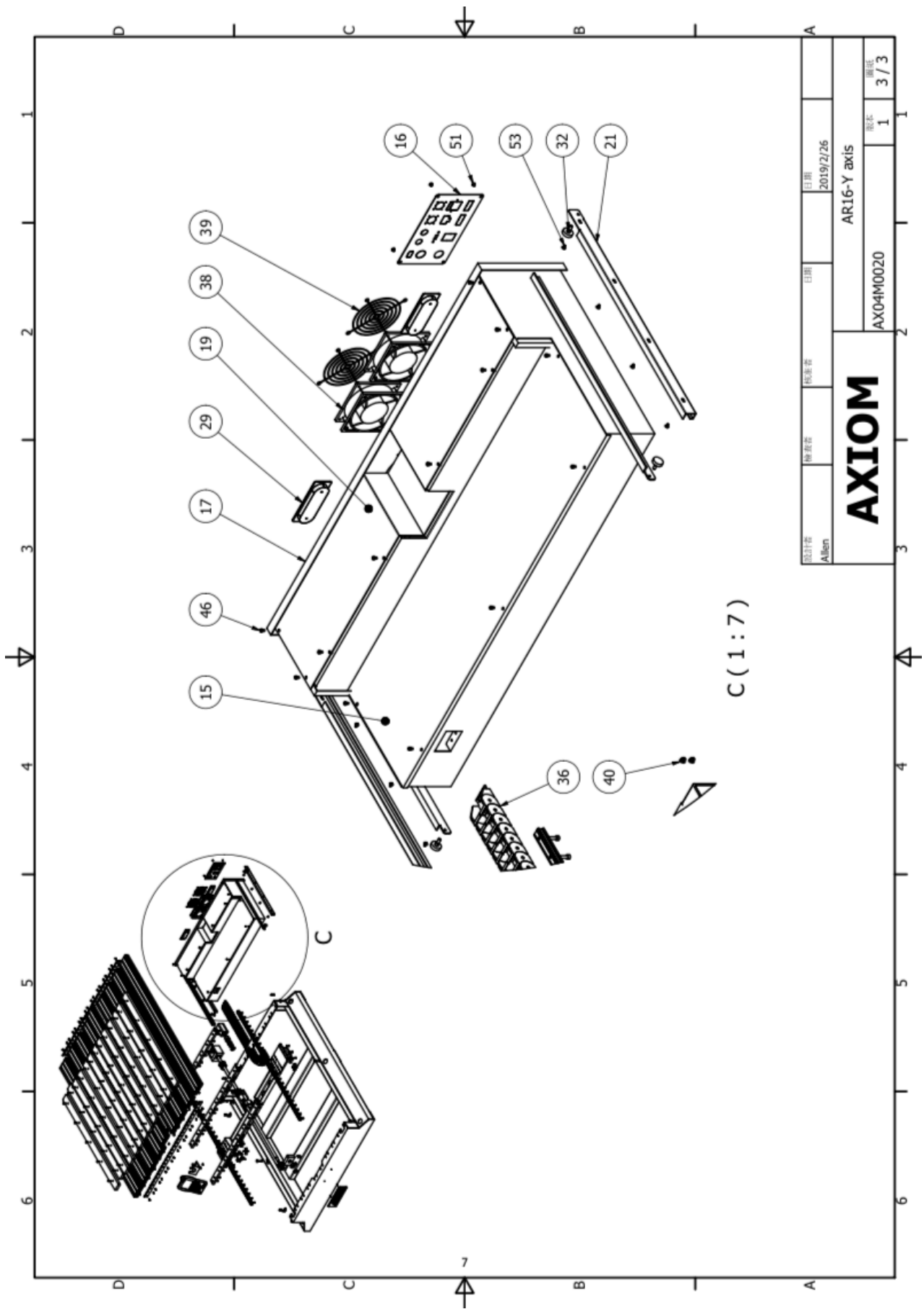

NO.	PART NO.	PART NAME	DESCRIPTION	QTY
1	AX0100582	WOOD PLATE(MIDDLE)		13
2	AX0400020	Y AXIS ALUMINIUM EXTRUSION TABLE (MIDD	1760MM	1
3	AX0400030	Y AXIS ALUMINIUM EXTRUSION TABLE	1760MM	8
4	AX0400350	Y AXIS BALL SCREW		1
5	AX0400350(2)	Y AXIS BALL SCREW(NUT)		1
6	AX0400250	BEARING COVER		2
7	AX0400170	Y AXIS MOTOR SEAT		1
8	AX0400270	Y AXIS BEARING SEAT		1
9	AX0400150	Y AXIS SLIDE SEAT		1
10	AX0400160	BASE		1
11	AX0400180	TABLE SIDE PLATE		2
12	AX0400450	ALUMINIUM EXTRUSION TABLE ENHANCE PLATE		3
13	AX0400260	SPACER		1
14	AX0400330	Y AXIS BALL SCREW SEAT		1
15	AX0400370	ELECTRICAL BOX REAR COVER		1
16	AX0400240	CONNECTOR PLATE		1
17	AX0400221	ELECTRICAL BOX		1
18	AX0400231	ELECTRICAL PLATE		1
19	AX0400361	ELECTRICAL BOX FRONT COVER		1
20	AX0400390	ELECTRICAL BOX SLIDE RAIL (LEFT)		1
21	AX0400400	ELECTRICAL BOX SLIDE RAIL (RIGHT)		1
22	AX0100220	SENSOR FIXED PLATE		2
23	AX0400280	SENSOR RESPONSE PLATE		2
24	AX0400530	CONTROLLER HANDLE		1
25	AX0400130	AXIOM NAME PLATE		1
26	X5F-RAB32-14x14	COUPLING		1
27	SME-L04030SAAU(400W)	SERVO MOTOR(400W)		1
28	B7004	BEARING		4
29	HP-003-1	HP-003		2
30	DA-1805NO	SENSOR		2
31	BNR20	LOCK NUT		2
32	H-30	IRON WHEEL		4
33	BGXS25BN-2-1480-N-Z0	Y AXIS LINEAR GUIDE		2
34	BGXX25BN	SLIDING BLOCK		4
35	CXHK8-10	CUSHION PAD		2
36	A0450.21 KR52-1390mm	Y AXIS DRAG CHAIN	1390MM	1
37	AX01C00103	HANDHELD CONTROLLER		1
38	Y0000071	4" Fan (220V)		2
39	Y0000033	4"FAN COVER		2
40	PP-002	PP DRAWER BUFFER PIN		4
41	HS-SCW-M4X10	HEX SOC HD SCR	M4x10	2
42	HS-SCW-M6X20	HEX SOC HD SCR	M6x20	60
43	HS-SCW-M3X6	HEX SOC HD SCR	M3x6	8
44	HS-SCW-M3X20	HEX SOC HD SCR	M3x20	4
45	HH-SCW-M10X45	HEX HD SCR	M10x45	6
46	HS-SCW-M4X6	HEX SOC HD SCR	M4x6	13
47	HS-SCW-M6X25	HEX SOC HD SCR	M6x25	8
48	HS-SCW-M6X16	HEX SOC HD SCR	M6x16	4

49	HS-SCW-M6X12	HEX SOC HD SCR	M6x12	18
50	HS-SCW-M5X12	HEX SOC HD SCR	M5x12	36
51	HS-SCW-M4X8	HEX SOC HD SCR	M4x8	4
52	FH-SCW-M6x25	HEX SOC FLAT HD CAP SCR	M6x25	65
53	THP-SCW-M4x8	TRUSS HD PHILLIPS SCR	M4x8	8
54	W-M3	FLAT WASHER	M3	8
55	P4M6	SQUARE NUT	M6	169
56	W-M10	FLAT WASHER	M10x45	6
57	HS-SCW-M6X16	HEX SOC HD SCR	M6x16	48

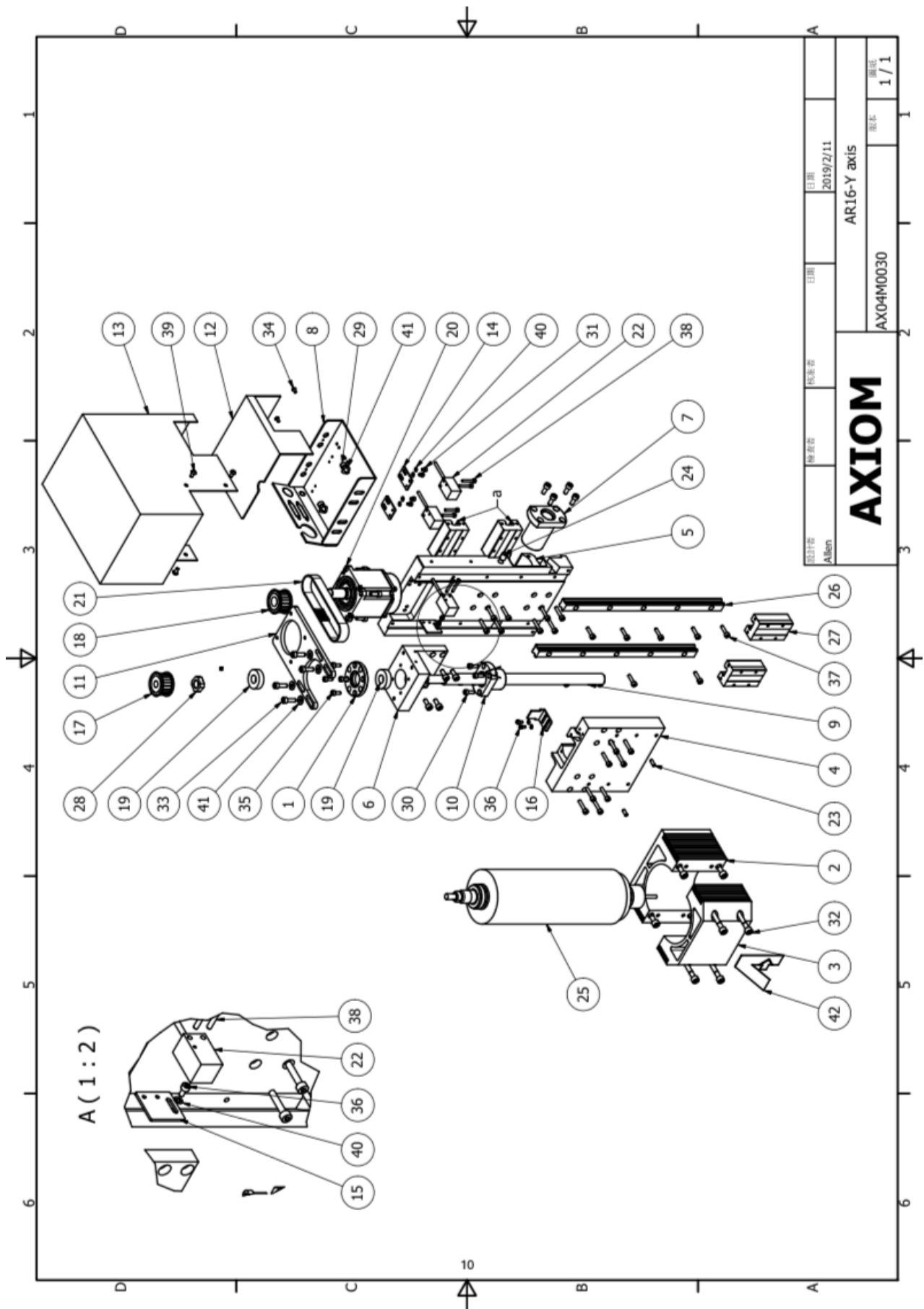

设计者 Allen	审核者	日期 2019/2/11	图号 AR16-Y axis
AX04M0030		版本 1/1	

AXIOM

NO.	PART NO.	PART NAME	DESCRIPTION	QTY.
1	AX0100131	BEARING COVER		1
2	AX0100091	SPINDLE MOUNT A		1
3	AX0100100	SPINDLE MOUNT B		1
4	AX0100083	Z AXIS SLIDE SEAT		1
5	AX0400040	X AXIS SLIDE PLATE		1
6	AX0400061	Z AXIS BEARING SEAT		1
7	AX0400320(NUT)	X AXIS BALL SCREW(NUT)		1
8	AX0102094	X AXIS DRAG CHAIN SEAT UPPER		1
9	AX0400050	Z AXIS BALL SCREW		1
10	AX0400050(NUT)	Z AXIS BALL SCREW(NUT)		1
11	AX0400070	Z AXIS MOTOR MOUNTING		1
12	AX0102101	X AXIS DRAG CHAIN COVER		1
13	AX0400080	Z AXIS TOP COVER		1
14	AX0100220	SENSOR FIXED PLATE		2
15	AX0400290	SENSOR FIXED PLATE		1
16	AX0100260	SENSOR RESPONSE PLATE		1
17	AX0400551	BELT PULLEY		1
18	AX0400561	BELT PULLEY		1
19	TPI-7001AHTP5	BEARING		2
20	SME-L04030SAAU(400W)	SERVO MOTOR(400W)		1
21	GBN275EV5GT-150_info-1-18-18	V-BELT		1
22	DA-1805NO	SENSOR		3
23	Pin4x10	PIN 4x10		2
24	Misumi_CXHK8-10	CUSHION PAD		2
25	GDZ-23-1C Φ80/2.2	SPINDLE MOTOR(2.2KW)		1
26	BGXS15BN-1-280-N-Z0	X AXIS BALL SCREW		2
27	BGXS15BN-1-280-N-Z0	SLIDE BLOCK		4
28	RN-12X1.0P	LOCK NUT		1
29	HS-SCW-M5X12	HEX SOC HD SCR	M5x12	14
30	HS-SCW-M4X12	HEX SOC HD SCR	M4x12	4
31	HS-SCW-M3X6	HEX SOC HD SCR	M3x6	4
32	HS-SCW-M6X35	HEX SOC HD SCR	M6x35	8
33	HS-SCW-M5X16	HEX SOC HD SCR	M5x16	4
34	HSB-SCW-M3x6	HEX SOC HD CAP SCR	M3x6	2
35	HS-SCW-M4X10	HEX SOC HD SCR	M4x10	4
36	HS-SCW-M3X8	HEX SOC HD SCR	M3x8	3
37	HS-SCW-M4X16	HEX SOC HD SCR	M4x16	25
38	HS-SCW-M3X18	HEX SOC HD SCR	M3x18	6
39	HS-SCW-M4X8	HEX SOC HD SCR	M4x8	4
40	W-M3	FLAT WASHER	M3	7
41	W-M5	FLAT WASHER	M5	6
42	AX01C00009	AXIOM TAG		1

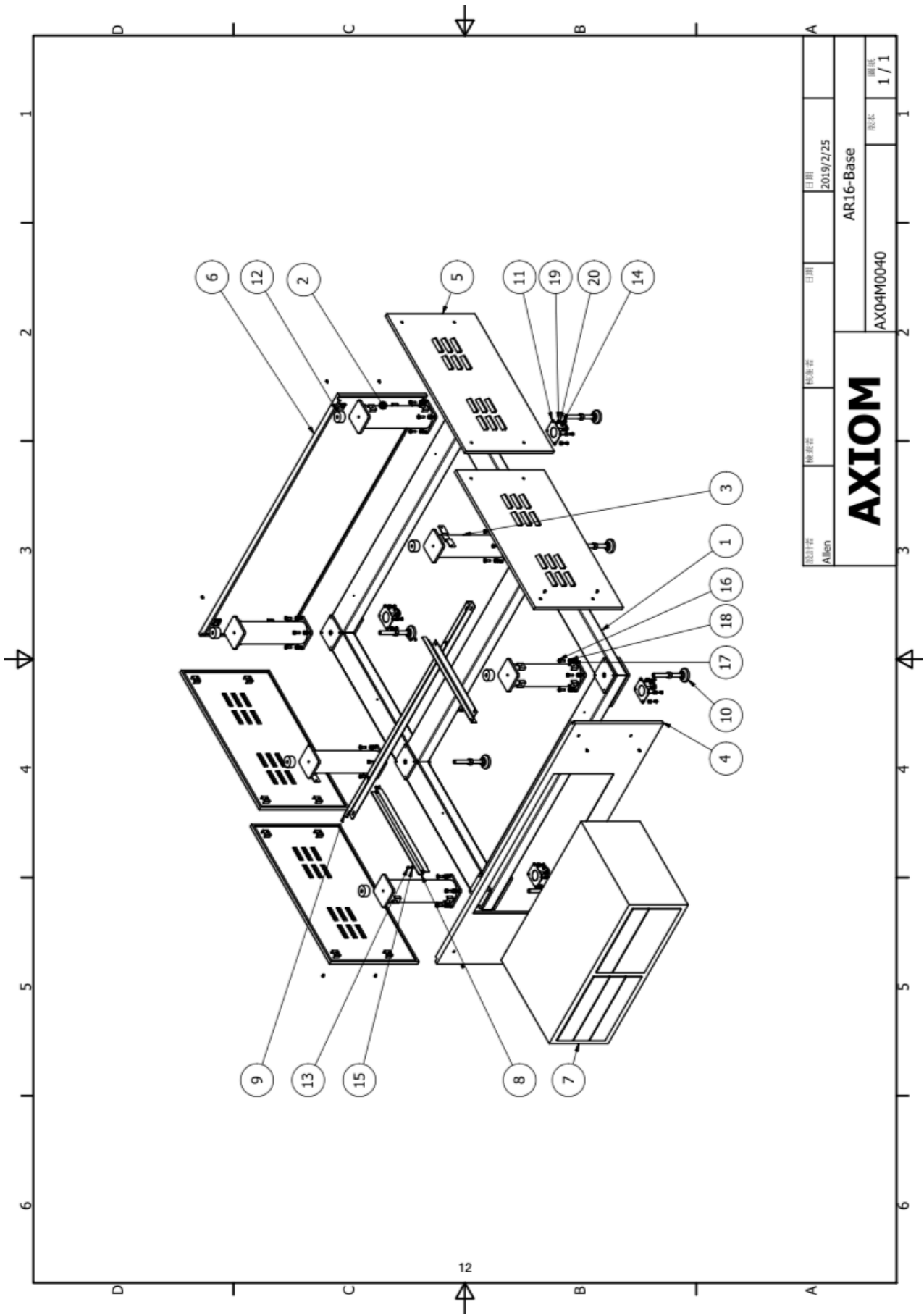

设计者 Allen	审核者	日期 2019/2/25	图号 AR16-Base
AX04M0040		版本 1 / 1	

AXIOM

No.	Part No.	Part Name	DESCRIPTION	Qty
1	AX0400410	BEAM (BOTTOM)		1
2	AX0400420	UPRIGHT CYLINDRICAL BEAM (EDGE)		4
3	AX0400490	UPRIGHT CYLINDRICAL BEAM (MIDDLE)		2
4	AX0400470	Stand FRONT PLATE (FRONT)		1
5	AX0400480	Stand PLATE (LEFT & RIGHT)		4
6	AX0400500	Stand PLATE (REAR)		1
7	AX0400460	TOOL BOX (AR16/32)		1
8	AX0400510	TOOL BOX SUPPORT BEAM (LEFT & RIGHT)		2
9	AX0400520	TOOL BOX SUPPORT BEAM (REAR)		1
10	TX102-1-6016-150	ANTI-DAMPING LEG		6
11	11090300201	NYLON CASTER		4
12	AX01C00044	DAMPING PLATE		6
13	HS-SCW-M5X6	HEX SOC HD SCR	M5x6	16
14	Hexagon Screw M6X12	HEX HD SCR	M6x12	16
15	W-M5	FLAT WASHER	M5x6	4
16	Hexagon Screw M8X25	HEX HD SCR	M8x25	24
17	W-M8	FLAT WASHER	M8x25	24
18	SSLW8	SPRING WASHER	W8	24
19	W-M6	FLAT WASHER	M6x12	16
20	SSLW6	SPRING WASHER	W6	16

Warranty:

Limited Warranty Coverage

Each Axiom Precision (the “Manufacturer”) CNC machine (“Machine”) and its components (except those listed below under limits and exclusions) is warranted against defects in material and workmanship for a period of 12 months from the date of sale. The foregoing is a limited warranty and it is the only warranty by manufacturer. Manufacturer disclaims all other warranties, express or implied, including but not limited to all warranties of merchantability and fitness for a particular purpose.

Repair or Replacement only

Manufacturer’s liability under this agreement shall be limited to repairing or replacing, at the discretion of manufacturer, parts or components. Shipment for items replaced under warranty is free, but the shipment method is at the discretion of Axiom Tool Group, Inc. In general delivery for domestic customers will be by UPS ground service or USPS. If overnight or express delivery is requested, additional fees will apply.

Direct phone support is part of the equation that allows us to provide high value at low cost. You must be comfortable with general electrical and mechanical repair concepts, including the appropriate safety procedures, before working on your machine. If you do not have the required skills you will need to find someone locally to assist you. We do not have factory technicians to send to your facility.

Limits and Exclusions of Warranty

Except as provided above, buyer agrees that all warranties express or implied, as to any matter whatsoever, including but not limited to warranties of merchantability and fitness for a particular purpose are excluded. Components subject to wear during normal use and over time such as paint, labels or decals, finish and condition, seals, bearings, spoil boards, flex cabling, etc., are excluded from this warranty. Axiom-specified maintenance procedures must be adhered to, in order to maintain this warranty. This warranty is void if the machine is subjected to mishandling, misuse, neglect, accident, improper installation, improper maintenance, or improper operation or application, or if the machine was improperly repaired or serviced. Warranty of general machine tolerances is void if the machine is disassembled or altered by customer.

Without limiting the generality of any of the exclusions or limitations described in other paragraphs, manufacturer’s warranty does not include any warranty that the machine or components will meet buyer’s production specifications or other requirements or that operation of the machine and/or components will be uninterrupted or error-free. Manufacturer assumes no responsibility with respect to the use of the machine and components by buyer, and manufacturer shall not incur any liability to buyer for any failure in design, production, operation, performance or otherwise of the machine or components other than repair or replacement of same as set forth in the limited warranty above. Manufacturer is not responsible for any damage to parts, machines, business premises or other property of buyer, or for any other incidental or consequential damages that may be caused by a malfunction of the machine or components.

Contact Us:

For software related inquiries, training videos, software updates, free projects and more...visit Vectric Ltd directly at:

<http://support.vectric.com>

Axiom Post Processors can be downloaded from the link below.

<https://www.axiomprecision.com/post>

Visit us online at:

www.axiomprecision.com

Need Assistance? The Axiom Precision CNC Support Team can be reached at:

support@axiomtoolgroup.com

For machine and accessory orders, the Axiom Precision Sales Team can be reached at:

sales@axiomtoolgroup.com



Axiom Tool Group, Inc.

427 New Sanford Rd

La Vergne, TN 37086

1-844-642-4902

BUILD BETTER STUFF.™

